

Data Aire Series

*Air and Water/Glycol Cooled
DX 6-30 ton*

Installation, Operation & Maintenance Manual



Data Aire, Inc.

230 W. BlueRidge Avenue

Orange, CA 92865

www.dataaire.com

dataaire
Precise by Design

CONGRATULATIONS ON THE SELECTION OF A DATA AIRE PRECISION ENVIRONMENTAL CONTROL SYSTEM. PROPER INSTALLATION, OPERATION AND MAINTENANCE OF THIS EQUIPMENT WILL ENSURE YEARS OF OPTIMAL PERFORMANCE.



This manual is intended to assist trained service personnel by providing necessary guidelines for this particular equipment. Service to Data Aire units should be done by qualified individuals with an adequate background in areas such as HVAC, electrical, plumbing and electronics, as applicable.



Service performed by unauthorized or unqualified technicians may void manufacturers' warranties and could result in property damage and/or personal injury.



Special care should be given to those area where these symbols appear.

Data Aire, Inc. reserves the right to make design changes for the purposes of product improvement, or to withdraw any design without notice.

Table of Contents

1.0	INSTALLATION	6
1.1	Room Considerations	6
1.2	Inspection	6
1.3	Rigging	6
1.4	Locating the Unit	7
1.4.1	Downflow Units	7
1.4.2	Upflow Units	8
1.5	Paperwork	8
1.6	Storage	8
2.0	PIPING	9
2.1	Air Cooled Unit Piping	9
2.1.1	Discharge Lines	9
2.1.2	Liquid Lines	10
2.1.3	Suction Lines	11
2.1.4	Connection Sizes, Air Cooled Units	11
2.1.5	Field Piping, Remote Condenser/Condensing Unit Above Evaporator	11
2.1.6	Field Piping, Remote Condenser/Condensing Unit Below Evaporator	12
2.2	Water/Glycol Cooled Unit Piping	12
2.2.1	Field Piping, Glycol System	13
2.2.2	Connection Sizes, Water/Glycol Cooled Units	13
2.2.3	Connection Sizes, Fluid Coolers	13
2.3	Auxiliary Chilled Water Coil Piping	14
2.4	Condensate Drain Piping	14
2.5	Humidifier Piping	14
2.5.1	Steam Generator Humidifier	14
2.5.2	Dry Steam Humidifier	14
2.6	Leak Testing	15
2.7	Evacuation	15
3.0	ELECTRICAL CONNECTIONS	16
3.1	Electrical Service	16
3.2	Nameplate Ratings	16
3.3	Grounding	16
3.4	Voltage Tolerance	16
3.5	Auxiliary Control Wiring	16
3.6	Remote Shutdown	17
3.7	Remote Alarm Contacts	17
3.8	Remote Sensors	18
3.9	Condensate Pumps	18
3.10	Condensate Probe	18
3.11	Water Sensing Cable	18

Table of Contents, cont'd

4.0	INSTALLATION OF REMOTE HEAT EXCHANGER	19
4.1	Rigging	19
4.2	Leg Assembly	19
4.3	Locating the Remote Heat Exchanger	19
4.4	Electrical Service	20
4.5	Air Cooled Condensers - Model DARC	20
4.5.1	Fan Speed Control	20
4.5.2	Ambient Thermostats	20
4.6	Fluid Coolers - Model DAFC	21
4.6.1	Fluid-Sensing Thermostats	21
4.6.2	Energy Saver Cooling	21
5.0	CHARGING	22
5.1	Voltage Phase Check	22
5.1.1	Evaporator	22
5.1.2	Secondary Heat Exchanger	22
5.2	Important Refrigeration Components	22
5.2.1	Expansion Valve	22
5.2.2	High Pressure Cutout Switch	22
5.2.3	Low Pressure Cutout Switch	22
5.3	Air Cooled Systems	23
5.3.1	Fan Speed Control System Charging	23
5.3.2	Flooded System Charging	23
5.4	Water/Glycol Cooled Systems	24
5.4.1	Water/Glycol Cooled Systems Charging	24
5.5	Refrigerant Handling	25
6.0	GLYCOL SYSTEMS	25
6.1	Glycol Concentration	25
6.2	Internal (Fluid) Volume - Downflow Models	26
6.3	Internal (Fluid) Volume - Upflow Models	26
6.4	Fluid Cooler Internal Volume	27
6.5	Copper Piping Internal Volume	27
6.6	Freezing Point of Aqueous Solutions	27
7.0	CONTROLS	28
7.1	dap4 Microprocessor Control Panel	28
7.2	Secondary Heat Exchangers	28
7.3	Wiring Diagrams	28

Table of Contents, cont'd

8.0	REGULAR MAINTENANCE ITEMS	29
8.1	Filters.....	29
8.2	Belts	29
8.3	Bearings	29
8.4	Humidifier Canisters	29
8.5	Fuses.....	30
8.6	Heating Elements	30
8.7	Refrigerant Filter Drier.....	30
9.0	WARRANTY	31
10.0	CONTACT DATA AIRE	32
	LINE SIZING CHART	33
	MONTHLY MAINTENANCE INSPECTION CHECKLIST	34
	QUARTERLY MAINTENANCE INSPECTION CHECKLIST.....	35
	SUPERHEAT and SUCTION PRESSURE TROUBLE SHOOTING GUIDE	36
	INDEX.....	37, 38

1.0 INSTALLATION



There is no intent on the part of Data Aire, Inc. to define local codes or statutes which may supersede common trade practices. The manufacturer assumes no responsibility for their interpretation. Consult local building codes and the National Electrical Code for special installation requirements.

1.1 Room Considerations

Precision air conditioning equipment is designed to control spaces within close tolerances of temperature and humidity. However, the room must be built with a proper vapor barrier. A film of polyethylene is often used on walls and ceilings. Walls and floors must also be painted with a vapor-seal paint. Failure to provide a vapor barrier can compromise space conditions.

Introduction of outside air into the space should be minimized. Outside air in excess of 5% of the total circulated air volume can have a significant effect on the overall space conditions and result in poor space control.

1.2 Inspection

This Data Aire unit has been factory run-tested and has gone through a comprehensive inspection prior to its packaging and shipment to ensure that it arrives in excellent condition. However, shipping damage can occur and a visual inspection of the outer crating immediately upon delivery should be performed.

Note any external damage or other transportation damage on the freight carrier's forms. Inspect the unit itself for internal damage. A claim should be filed with the shipping company if the equipment is damaged or incomplete.

Loose items such as remote control panels, disconnect switch handles, spare belts and spare filters are packed inside the unit. Refer to the yellow shipping tag located on the unit door for details.



Freight damage claims are the responsibility of the purchaser. Action to recover losses should be filed immediately. Please notify factory personnel of any claims.

1.3 Rigging

Move the unit in its upright position to the installation site. It is recommended that the unit be protected from damage to the decorative doors during any storage or moving. Removal of the decorative doors is easily accomplished and may be done when moving equipment.

The shipping skid should be left in place if the unit is being moved with a forklift. If the unit is being lifted, use spreader bars to prevent damage to the doors and panels.

The unit has 3/4" holes in the shipping skid to which casters with 3/4" stems can be attached. This allows easy movement down halls, into elevators and through doorways. If clearance is a problem

the casters may be inserted directly into the bottom of the 1” tubular steel corner posts at the bottom of the unit.



Warning: Improper lifting or moving of equipment may result in damage to decorative doors, panels or frame members.

1.4 Locating the Unit

When installing the unit, sufficient space must be allowed for airflow clearance, wiring, plumbing, and service access. It is recommended that each side and front have a clearance of at least 36” to allow the doors to swing open and for servicing the unit.

The doors on some sides may not require as much service clearance. Refer to the particular unit component breakdown drawings for assistance. Rear clearance is not required, but 1” to 2” of clearance is suggested.

For the best air distribution, the unit should be centered against the longest wall, as close to the heat load as possible, unless the unit is ducted. The unit should not be placed near any corner of the room or at the end of a long, narrow room. Multiple units should be evenly spaced, as far apart as possible.



Note to Installing Contractor: Condensation formation and frequent humidifier flushing are normal functions of this equipment. Proper drain connections must be made to ensure proper removal. Unit will require water connections for condensate removal and possibly for humidifier makeup water, condenser water, chilled water and/or hot water. Installation of units above equipment that could sustain water damage should be avoided.

1.4.1 Downflow Units

Downflow units will typically sit on an elevated flooring system known as a raised floor. The unit discharges air downward which pressurizes the raised floor and channels upward through perforated floor tiles. Location and quantity of perforated tiles will dictate proper air distribution. If the raised floor is strong enough to support the unit and local codes permit, the unit can be placed directly on top with cutouts made for the discharge openings.

There may be additional support required in the form of adjustable jackstands. These are adjustable, threaded leveling rods which support the unit in each of the corners and in the center on longer length units. Tighten the locknuts provided with each jackstand. The baseplate can rest on the floor or on vibration isolation pads.

Floorstands are also a way of supporting the unit. These are ordered to the height of the floor with leveling rods to allow adjustment. The floorstand has lips in each corner to align with the unit which is placed on top. It is recommended that the unit frame be bolted or screwed to the floorstand from below. Local building codes may dictate this procedure. After installation, the raised floor is typically built around the unit.



The raised floor serves as the distribution plenum for air on downflow units. Cables, piping, wiring raceways, inadequate floor height and any other restrictions can inhibit proper airflow. Care should be taken to avoid restrictions.

1.4.2 Upflow Units

Upflow units will typically be supported by vibration isolation pads and/or floorstands which may also include leveling screws. An air discharge plenum may be factory provided which ships loose and must be attached at the top of the unit frame.

Alternately, an air distribution plenum must be field fabricated with supply grilles to distribute the air. Units are shipped with a drive package to overcome external static pressure. Adjustments to the blower speed may be required to adjust to actual conditions.

1.5 Paperwork

Each Data Aire unit ships with a start-up sheet that should be completed during installation. Also included in the paperwork is a warranty/information packet that provides important wiring diagrams, specific component literature, warranty registration cards and other valuable paperwork, including a copy of this Installation/Operation and Maintenance manual.

A yellow tag is attached to the outside decorative door to indicate articles that may have been packaged and shipped loose within the unit cabinet. Typically this would be jackstands, condensate pumps and other loose components that are not factory mounted.

1.6 Storage

Your Data Aire equipment comes ready for immediate installation. In some instances it may be necessary to store the equipment for a period of time. If you must store the equipment it should be done in a dry area, out of the weather, protected from damage by other equipment in storage or transportation equipment, never stacked, and avoid frequent relocation.

If equipment is stored for longer than 30 days special precautions must be taken to avoid coil damage. All coils should be charged and sealed with a low pressure (1-3 psig) inert gas, such as nitrogen. This prevents contaminants from entering the coils; then when the seal is broken at installation, the rush of escaping gas verifies the coil is still leak free. If coils are not charged and sealed condensation mixes with air pollutants forming a weak acid and over time can cause pin hole leaks to develop in the coil tubes.

When equipment is installed after storage caution should be taken to inspect and replace, if required, rubber hoses and belts. All moving parts, such as blowers and motors, should be hand tested to ensure that they are free and clear prior to start-up. Finally, verify that all lubrication is fresh and full.



It is the responsibility of the installing contractor to return the start-up sheet and warranty registration card to Data Aire for proper activation of the unit warranty. Failure to do so may cause delays and in some cases void the warranty.

2.0 PIPING

2.1 Air Cooled Unit Piping

Refer to the attached line sizing chart on page 32 for a guideline for sizing refrigerant lines. The ultimate responsibility for line size selection is that of the installing contractor or design engineer. Data Aire does not assume this responsibility. The chart covers distances up to 200 equivalent feet. For installations beyond this distance, consult ASHRAE or similar references.

	Standard piping practice must be used to ensure proper oil return and efficient operation. The interconnecting lines to the remote air cooled condenser must be installed by a qualified refrigeration mechanic.
---	--

2.1.1 Discharge lines

Discharge lines, also called hot gas lines, should be trapped at the top (inverted) and bottom as well as every 15 to 20 feet (4.6 to 6.1 m) of vertical rise. Discharge check valves are required on all installations, especially those where there are long pipe runs or cold climates.

For air-cooled units built after 3/14/2017, the discharge check valves are already installed inside the evaporator section and do not need to be installed external to the unit. For units built before this date, the check valves must be field supplied and installed externally to the evaporator section. If there is doubt as to whether or not the check valve is already installed in the unit, look for it on the hot gas line close to the exit point of the unit (see example picture below). The externally installed check valve should be placed from six (6) to ten (10) feet (1.8 to 3.1 m) from the compressor.



Note: Picture is only intended to show an example of a common check valve installation. It may not represent your specific unit, check valve size, location or orientation.

The check valve will prevent flow from the condenser to the compressor during the “off” cycle.

The discharge, suction and liquid lines need to be refrigerant grade copper and in accordance with local code. All refrigeration piping should be installed with high temperature brazed joints. When brazing, a supply of nitrogen gas needs to be fed through the refrigerant lines. Be sure to open the other end of the refrigerant line to allow the nitrogen to bleed off and not pressurize the piping. Prevailing good refrigeration practices should be employed for piping support, leak testing, dehydration and charging the refrigerant circuits. During the installation the lines should be capped off and filled with dry nitrogen at the end of each day’s work or until the system is completed and sealed.

Data Aire recommends a silver/phosphorus/copper alloy with 5 to 15% silver be used to braze the refrigerant line sets to the indoor and outdoor units. Nitrogen needs to be flowing through the lines to eliminate carbon deposit buildup on the inside of the joints. Carbon could contaminate the refrigerant and restrict the metering device.

Piping must be supported within 18” of the inlet and outlet connections. The inlet connection is located on the top header of all units. The discharge outlet is located at the bottom of the header.

Discharge line pressure drop should not exceed 6 PSI for R-407C and 9 PSI for R-410A. Recommended gas velocity for proper oil return is 1,000 FPM. Slope horizontal lines downward in the direction of refrigerant flow (1/2” for every ten feet of line length). Discharge lines do not require insulation but due to the high temperatures of the refrigerant inside the line, the pipes may be insulated to protect against burns to individuals near or around the lines.

2.1.2 Liquid lines

Liquid line size is determined by pressure drop and velocity. The liquid line pressure drop for R-407C should not exceed 5 PSI or 9 PSI for R-410A. The recommended liquid velocity should be between 200 and 300 FPM. To avoid excessive liquid line pressure drop, the air cooled condenser should be located above or at the same level as the evaporator. Insulation of liquid lines is not required but can be useful in preventing excessive sub-cooling or flashing on long exposed pipe runs.

2.1.3 Suction lines

Some applications call for the compressor(s) to be mounted as part of condenser (more commonly referred to as a condensing unit). Condensing units require field piping of liquid and suction lines. Suction lines are trapped similarly to discharge lines. Common practice for suction line selection and installation should be followed. Suction line should always be insulated.

2.1.4 Connection Sizes, Air Cooled Units

Model	Hot Gas	Liquid	Model	Hot Gas	Liquid
DAA* 06	1/2"	1/2"	DAA* 16	3/4"	5/8"
DAA* 08	5/8"	1/2"	DAA* 20	3/4"	5/8"
DAA* 10	5/8"	1/2"	DAA* 26	7/8"	7/8"
DAA* 13	5/8"	5/8"	DAA* 30	7/8"	7/8"

* D - downflow, U - upflow

Field connections at the indoor evaporator and remote condenser or condensing unit will not necessarily be the same as the field pipe size required. In some cases these will vary significantly.

2.1.5 Field Piping, Remote Condenser/Condensing Unit Above Evaporator

NOTES:

1. THIS IS THE RECOMMENDED PIPING. ALL PIPING TO BE PER LOCAL AND/OR STATE CODE.
2. CONDENSER TO BE NO MORE THAN 60 FEET ABOVE EVAPORATOR.
3. FOR UNITS BUILT AFTER APRIL 2017, THE CHECK VALVES ARE INCLUDED INTERNALLY IN THE EVAPORATOR SECTION.
4. SLOPE HORIZONTAL LINES DOWNWARD IN THE DIRECTION OF THE REFRIGERANT FLOW, 1/8" FOR EVERY 10 FEET OF LINE LENGTH.
5. INVERTED TRAP TO EXTEND 8" ABOVE THE BOTTOM OF THE CONDENSER COIL.

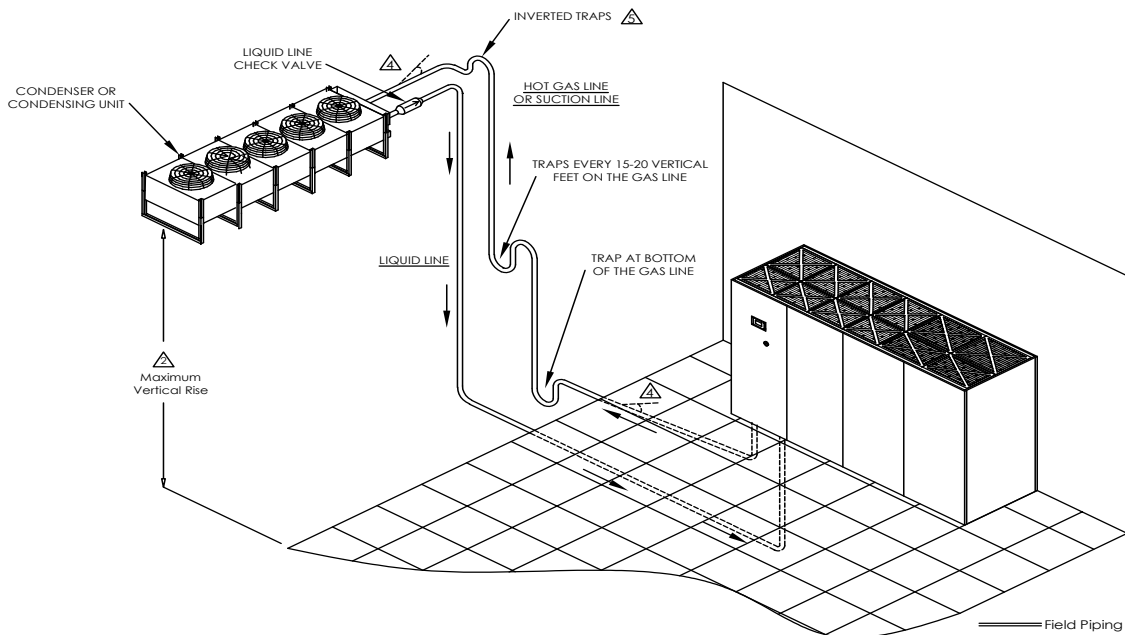

One Circuit Shown

2.1.6 Field Piping, Remote Condenser/Condensing Unit Below Evaporator

NOTES:

1. THIS IS THE RECOMMENDED PIPING. ALL PIPING TO BE PER LOCAL AND/OR STATE CODE.
 2. CONDENSER TO BE NO MORE THAN 15 FEET BELOW EVAPORATOR.
- ⚠ SLOPE HORIZONTAL LINES DOWNWARD IN THE DIRECTION OF THE REFRIGERANT FLOW, 1/2" FOR EVERY 10 FEET OF LINE LENGTH.
- ⚠ INVERTED TRAP NEEDED ON SUCTION LINE WHEN COMPRESSOR IS OUTDOORS ONLY.

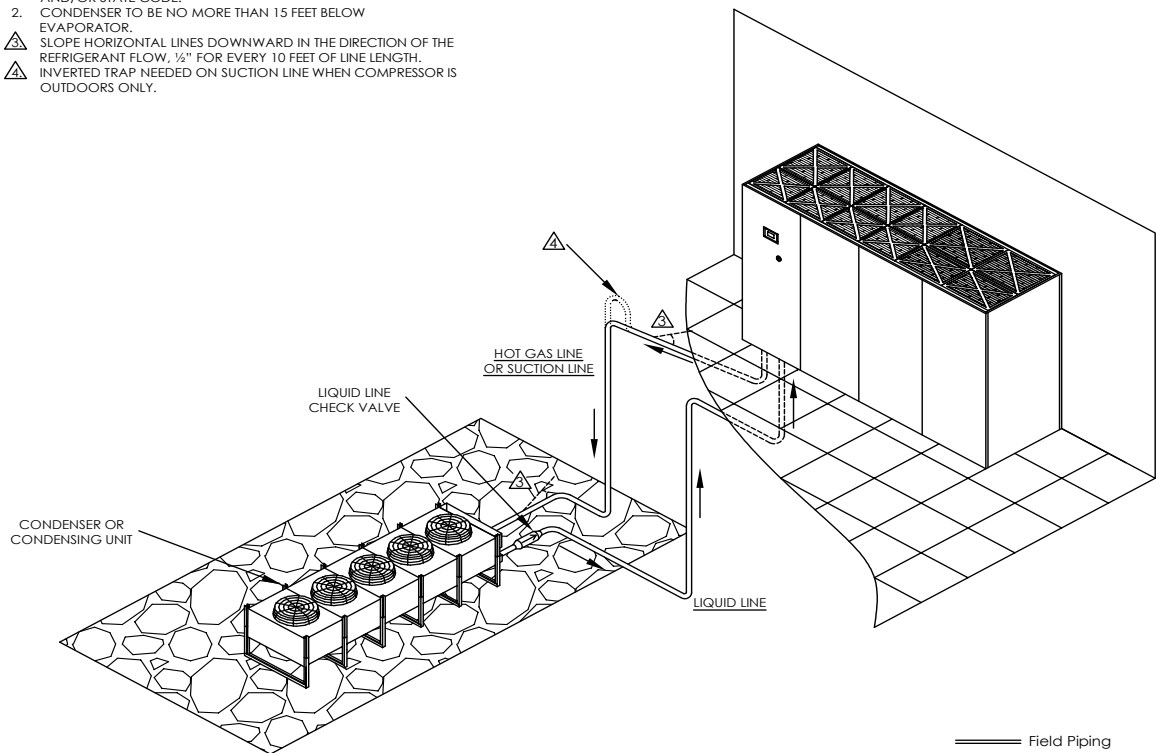

2.2 Water/Glycol Cooled Unit Piping

The required field installed fluid cooler pipe sizes may or may not be the same as the connection sizes at the fluid cooler. (Refer to 2.2.2 and 2.2.3 for connection sizing). This will depend on the length of pipe and the calculated pressure drop of peripheral components.

Water cooled units may also be connected to building water or tower water sources. Pipe size will depend on length of run and the maximum water flow required.

Shut-off valves (field provided) should be installed within a few feet of the inlet and outlet connections of the evaporator to allow the unit to be isolated for service. Drain/fill valves should be located at the lowest point on the connected piping.

All water/glycol cooled units are shipped with plate/fin heat exchangers as standard equipment. A strainer is shipped loose and is to be field installed in the supply line with shut-off valves (field provided) before and after the strainer. The strainers and water/glycol piping must be cleaned on a periodic basis. If the unit is shipped with shell and tube condensers, strainers are not required nor shipped with unit.



One of the most common problems in a water/glycol system is the presence of air in the condenser water loop. Air vents must be installed in various locations in the piping system to purge the air.

Glycol system piping may include a centrifugal pump (or pumps for redundancy). Pumps must be primed before operating per the pump manufacturers guidelines.

2.2.1 Field Piping, Glycol System

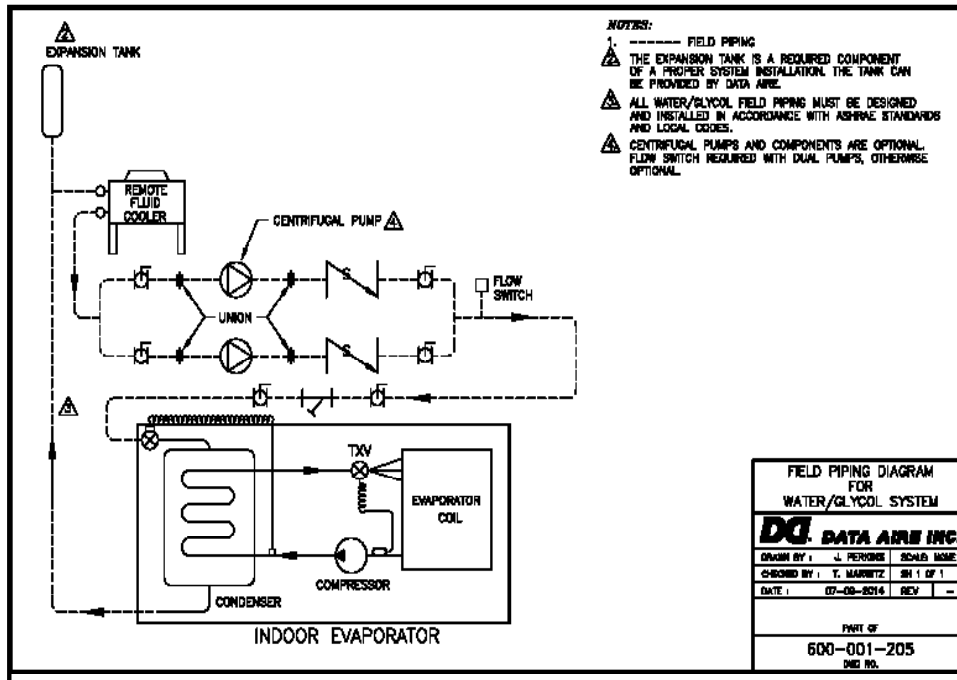

2.2.2 Connection Sizes, Water/Glycol Cooled Units

Evaporator Model	Water IN and OUT Connections, OD	Evaporator Model	Water IN and OUT Connections, OD
DAW/G 06	1-5/8"	DAW/G 16	2-1/8"
DAW/G 08	1-5/8"	DAW/G 20	2-1/8"
DAW/G 10	1-5/8"	DAW/G 26	2-1/8"
DAW/G 13	1-5/8"	DAW/G 30	2-1/8"

2.2.3 Connection Sizes, Fluid Coolers

Fluid Cooler Model	Water IN and OUT Connections, OD	Fluid Cooler Model	Water IN and OUT Connections, OD
DAFC 06	1-5/8"	DAFC 37	2-5/8"
DAFC 07	1-5/8"	DAFC 40	2-5/8"
DAFC 09	1-5/8"	DAFC 44	2-5/8"
DAFC 11	2-1/8"	DAFC 50	2-5/8"
DAFC 15	2-1/8"	DAFC 57	2-5/8"
DAFC 17	2-1/8"	DAFC 61	2-5/8"
DAFC 21	2-1/8"	DAFC 75	2-5/8"
DAFC 24	2-1/8"	DAFC 80	2-5/8"
DAFC 28	2-1/8"	DAFC 88	2-5/8"
DAFC 30	2-5/8"	DAFC 100	2-5/8"

 Models DAFC 57 and larger are double-wide units. Although the header connection for each section is 2-5/8", each unit comes with a factory provided manifold kit with 3-1/8" field connections.

2.3 Auxiliary Chilled Water Coil Piping

Units with an Auxiliary Chilled Water cooling coil require a separate source of chilled water. These chilled water connection sizes will be equal to the condenser water connection sizes on the chart in Section 2.2.2. Units with an Energy Saver cooling coil have shared piping with the condenser supply and therefore do not require a separate water source.

All chilled water pipes have a cap installed on the end of the pipe for pressure testing the system. These caps need to be removed before installing the water piping to the unit. Use a tube cutter for smaller pipes and reciprocating saw with a metal cutting blade for larger pipes or if there is a clearance problem. All connections need to be cleaned before connections are brazed together.

2.4 Condensate Drain Piping

Every indoor unit has a 3/4" copper stub provided for condensate removal. A union is recommended at the field connection which will permit easy disconnection from the unit for cleaning.

A trap should be built into the drain line to prevent air from backing up into the unit. Drain lines should be pitched downward not less than 1/4" for each ten feet of horizontal run. Do not reduce the size of the drain line. Where local code permits, PVC pip may be used.

Some applications have no convenient means of allowing a gravity drain. In this case, a condensate pump can be used. These come either factory mounted or shipped loose. Factory mounted condensate pumps do not require a separate power source.

Condensate pumps shipped loose (or field provided) typically require a dedicated 110 volt power source. Field pipe connections must be made to the pump discharge connection. A check valve must be installed to prevent short cycling. See also condensate pump electrical requirements in Section 3.9.

2.5 Humidifier Piping

2.5.1 Steam Generator Humidifier

The standard humidifier on Data Aire systems is a steam generator type with a disposable cylinder. The humidifier makeup water should be brought to the humidifier through the field connection opening using 1/4" copper tubing. A compression fitting is provided at the humidifier.

A shutoff valve should be provided outside the air conditioner to allow disconnection for service. An in-line water pressure regulator and strainer should be installed. Water pressure should be set between 30 and 80 PSI.

The humidifier has a drain at the bottom which is factory piped to the main condensate drain line. The dispersion tube also has a drain line. No additional field piping is required.

2.5.2 Dry Steam Humidifier

The optional dry steam type humidifier requires a strainer on the inlet steam line. An outlet connection with a field-provided steam trap is also required. Steam pressure is typically 10-15 psi.

2.6 Leak Testing

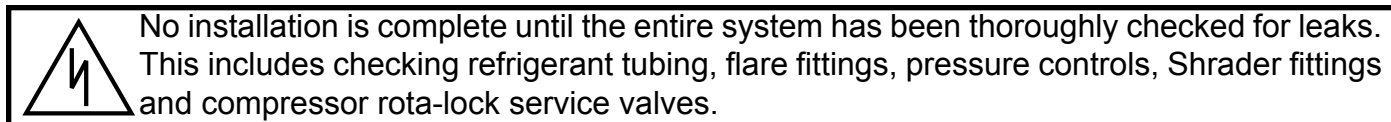

In addition to the refrigeration system, check all condenser water lines, humidifier makeup lines, condensate lines, condensate pumps, chilled water lines, centrifugal pumps, and fluid coolers as applicable.

With recent changes in the handling and recovery of refrigerant, it is not permissible to release refrigerant into the atmosphere. Many leak-test methods recommended in the past are no longer possible. Current standard practices must be used.

Pressurize system circuit to 150 PSIG (1034kPa) by using dry nitrogen with a trace of refrigerant. Check the entire system for leaks with suitable leak finder, (per local code) including but not limited to all braze joints, caps, fittings and flare nuts on both field and factory furnished components. After completion of leak testing, release test pressure and pull a vacuum on the system.

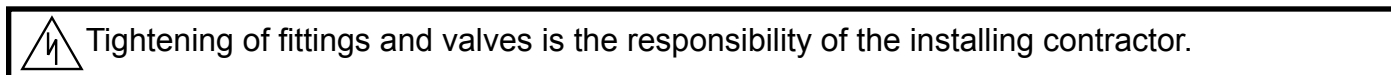

2.7 Evacuation

Evacuate the refrigerant lines, condenser coil and evaporator coil to 250 microns or lower (a micron gauge and 2-stage vacuum pump are required). Valve off and turn off the vacuum pump and wait for at least 15 minutes to make sure the micron gauge reading does not go back above 700 microns. If it does, restart the vacuum pump and evacuate until the system reaches 250 microns. If the system still does not hold the pressure below 700 microns the system needs to be rechecked for leaks.

After the system has been satisfactorily evacuated the lines can be charged with refrigerant. Connect the pressure gauge manifold set to the high and low ports near the compressor. Connect the charging line to the refrigerant tank and set it for liquid feed. Open the refrigerant tank valve and purge the line at the manifold, then open the high side valve on the manifold only and allow the refrigerant flow until the system pressure equalizes. At this point the system will have 75 to 80% of the total refrigerant charge. Start the blower(s) and then the compressors checking the operating pressures and temperatures.

NOT APPLY POWER TO THE COMPRESSOR WHEN IN A VACUUM

3.0 ELECTRICAL CONNECTIONS



Before proceeding with the electrical connections, make certain that the volts, hertz, and phase correspond to that specified on the unit electrical nameplate. Use copper conductors only.

3.1 Electrical Service

Check to be sure the service provided by the utility is sufficient to handle the additional load imposed by this equipment. Most units with secondary heat exchangers will require a separate power source and field-provided, interconnecting control wires. See section 3.5 below.

Remote condensers will typically require one power source. Glycol systems with fluid coolers and loose pump(s) typically require one power source for the fluid cooler and will require one additional source for a single pump or two additional sources for dual pumps. Systems where the pump(s) are mounted and piped integral to the fluid cooler will usually require a single power source.

3.2 Nameplate Ratings

Refer to the unit electrical nameplate for equipment electrical requirements. Minimum Circuit Ampacity (MCA) also known as wire sizing amps, will dictate the minimum required wire gauge. Maximum Overcurrent Protection (MOP) device amps will dictate the maximum circuit breaker or fuse size.

3.3 Grounding

The unit cabinet must have an uninterrupted true earth ground. An electrical ground wire of adequate size must be connected to the ground lug provided inside the main electrical box.

3.4 Voltage Tolerance

The supply voltage to the unit must be within tolerance; -5% to +10% for 208-230 voltage, +10% for 460 volts. Phase to phase imbalance must not exceed 3%. The local utility company should be contacted for correction of improper line voltage. Deviation from ratings can cause premature failures and possibly void unit warranty.

3.5 Auxiliary Control Wiring

The interconnection of auxiliary control wiring for remote heat exchangers (condensers and fluid coolers) requires the connection of two (2) - 18-gauge wires for installations up to 150 feet (45 m) or 16-gauge wires for installations from 151 feet (46 m) up to 200 feet (61 m) from the electrical control box of the indoor evaporator to the electrical control box of the remote heat exchanger. Condensing units (i.e., where the compressor(s) are mounted in the remote heat exchanger) will typically require (4) or more wiring connection points and may require heavier gauge wire. In this case, the installing contractor must follow the applicable electrical codes to determine the required wire gauge.

Because of the wide variety of indoor evaporators and remote heat exchangers offer by Data Aire, the installing contractor must refer to the schematic which is provided inside the electrical control box of each unit, for the required auxiliary control wiring interconnection terminal points.

Examples:

Figure 1 - Typical Remote Heat Exchanger Interconnection Points

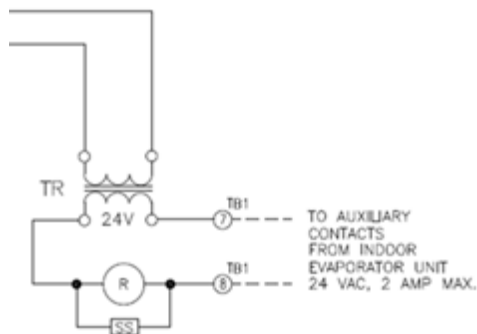
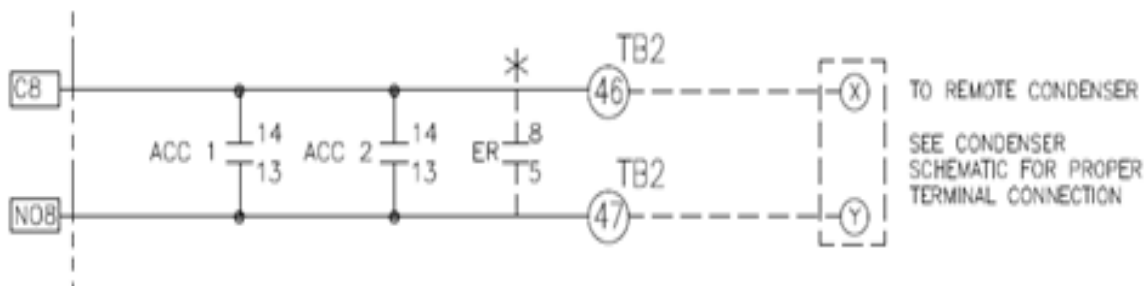

Figure 2 - Typical Indoor Evaporator Interconnection Points



3.6 Remote Shutdown

Every Data Aire evaporator has remote shutdown contacts. These are intended for a field supplied dry contact or switch to be wired across two terminals. When the contact or switch opens, the control circuit power is interrupted and the unit shuts down, including the control panel. The control circuit is 24 VAC and the field provided contact or switch should have a minimum rating of 10 amps.

The remote shutdown contacts are always terminals #1 and #2 on the terminal block designated TB2. The unit will ship with a factory wired metal jumper clip that connects terminal #1 to terminal #2. Remove this clip prior to installing the field wires.

3.7 Remote Alarm Contacts

The dap4 microprocessor control provides four (4) remote alarm output contact that can be field accessed on terminals # 11, 12 and 13 of terminal block TB2. Terminal # 12 is a Normally Closed (NC) open on Alarm dry contact. Terminal # 13 is a Normally Open (NO) close on alarm dry contact. Both are intended to be used in a control circuit not exceeding 2 amps at 24VAC. These programmable output contacts will close or open on a failure and will remain open or closed until the alarm is no longer present.

Three (3) additional alarm output contacts are available. The terminal designations for these alarms contacts are as follows:

- # 40 – Remote Alarm 2 (Common)
- # 41 – Remote Alarm 2 (Normally Closed)
- # 42 – Remote Alarm 2 (Normally Open)
- # 43 – Remote Alarm 3 (Common)
- # 44 – Remote Alarm 3 (Normally Closed)
- # 45 – Remote Alarm 3 (Normally Open)
- # 48 – Remote Alarm 4 (Common)
- # 49 – Remote Alarm 4 (Normally Closed)
- # 50 – Remote Alarm 4 (Normally Open)

3.8 Remote Sensors

Remote sensors are optional. Although existing unit mounted sensors can be removed for remote mounting, the remote sensor option provides a more convenient means of field installation. This is because the sensors are already connected to a predetermined length of cable and come mounted in a remote sensor enclosure. The temperature and humidity sensors require a total of five wires, these should be a twisted, shielded cable.

3.9 Condensate Pumps

Condensate pumps which ship loose normally require a separate source of 110 volt power. Always check the pump power requirements before connecting power. Condensate pumps are available in other voltages.

Condensate pumps may also come unit mounted and powered. While no outside power source is required, field piping is still a requirement. Condensate pumps are wired to display a “High Condensate Water Level” alarm. The wiring for this must be done in the field on pumps that ship loose. Factory mounted pumps come pre-wired.

3.10 Condensate Probe

A condensate probe for sensing under floor water is included with this unit. This comes in a plastic bag, with about 15 feet of coiled-up wire. The probe is a flat plate that is typically placed below the unit in a location where water is likely to accumulate.

Place the probe flat on the floor on top of a thin layer of non conductive silicone. Secure the attached wires where necessary. A longer length of wire may be used if required.



Note: Failure to uncoil the length of wire attached to the condensate probe can result in a nuisance water-detected alarm. If the probe is not going to be used it should be disconnected.

3.11 Water Sensing Cable

Some units may be equipped with a water sensing cable. The cable is connected to the terminal board and ready for installation. Cable lengths will vary depending on the original order and specifications. Typically, the cable is installed around the unit’s perimeter. The cable is supplied with holding clips. Care should be taken when installing the cable. Be sure the cable is not touching metal and/or any debris under the raised floor.

4.0 INSTALLATION OF REMOTE HEAT EXCHANGER

Air cooled condensers and fluid coolers have individual Selection Guide/Operation and Maintenance manuals which should be referred to for more complete details.

4.1 Rigging

Secondary heat exchangers matched with evaporators of this size are typically remote, outdoor type. The heat exchanger should be moved to its (typically rooftop) mounting location using a crane or fork lift. Each fan section has heavy, steel leg supports with lifting holes at the top.

Do not lift with a choke sling around the unit. Spreader bars are recommended for lifting multiple fan units. Under no circumstances should the coil headers or piping be used for lifting the unit. Ideally, the unit should be kept in its shipping crate until it is ready to be set in place.

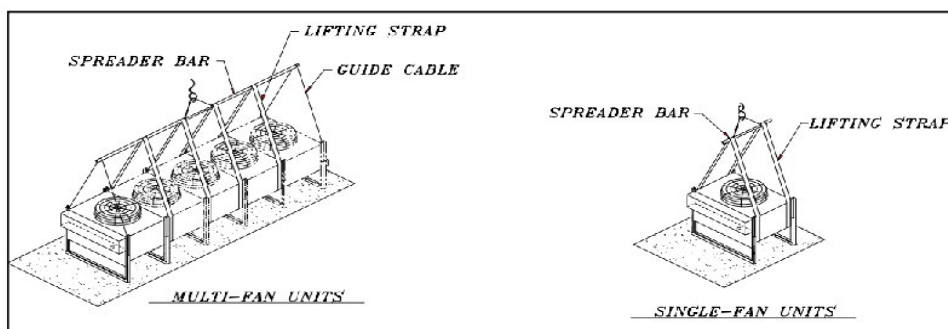

4.2 Leg Assembly

The legs must be unbolted from their collapsed shipping position and extended prior to placing the unit on its pad. Each leg extends down approximately 18" and reattaches using the same bolts. **Note:** Failure to extend the legs will result in poor air distribution over the cooling coil resulting in significant capacity reduction.

NOTE: Failure to extend the legs will result in poor air distribution over the cooling coil resulting in significant capacity reduction. **DAMAGE CAUSED TO THE COMPRESSOR(S) DUE TO OVERHEATING IS NOT COVERED BY DATA AIRE'S WARRANTY.**

Concrete pads are often used to provide support for the heat exchanger. Bolt holes in the bottom of each leg can be used to anchor the unit.

4.3 Locating the Remote Heat Exchanger

The remote heat exchanger must be located in an area that will ensure free air flow into and out of the heat exchanger plus adequate service access clearance. Short circuiting of the air flow or the intake of warmer air from another unit will seriously degrade the performance of the air cooled heat exchanger.

Do not locate the heat exchanger in a location that is bordered by tall obstructions (i.e. higher than 10 feet) on no more than two sides. See figure at right for minimum clearance from obstructions and between units. With proper clearance on all sides, two units can be placed at least 48 inches apart.

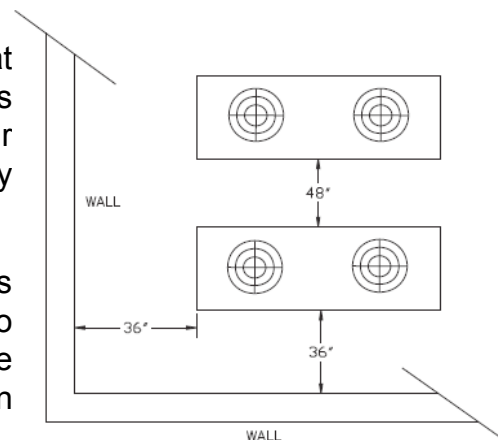

Noise factors should also be considered when locating an air cooled heat exchanger. Proximity to windows, walls and surrounding structures can cause objections by the occupants. An acoustical expert should be consulted when noise is of a particular concern.

Air cooled heat exchangers should be placed at a level that is higher than the indoor evaporator. The mounting of the remote heat exchanger more than 10 feet below the evaporator is not recommended. Excessive liquid line pressure drop can cause poor evaporator performance.

Piping must be supported within 18 inches of the inlet and outlet connections. The inlet connection is located on the top header on all remote heat exchangers and the outlet connection is located on the bottom header of all units.

4.4 Electrical Service

Refer to Sections 3.1 to 3.5 for information regarding line voltage and control voltage wiring details.

4.5 Air Cooled Condensers - Model DARC

4.5.1 Fan Speed Control

The standard Data Aire condenser (DARC) utilizes a fan speed controller. On single fan condensers this is the only means of control.

Multiple fan condensers are provided with fan speed control on the first motor (nearest the header). The fan speed control is pre-programmed and there is no need to adjust the unit in the field. The header fan will cycle with the head pressure of the unit.

Units shipped with R-407C the starting pressure is 220 PSIG and the fan will be at full speed at 285 PSIG. Units shipped with R-410A the starting pressure is 320 PSIG and the fan will be at full speed at 400 PSIG. The second fan operates in conjunction with the speed controlled fan. The fan speed control powers ON the auxiliary and shifts the speed controlled fan to a new start pressure.

4.5.2 Ambient Thermostats

Additional motors (subsequent to the fan speed control operated motors) multiple fan heat exchangers are cycled by ambient sensing thermostats. These thermostats have a capillary tube with remote sensing bulb. They function best with the sensing bulbs mounted below the coil, away from exposure to direct sunlight with the bulb in the vertical position. An instruction set comes as part of a mounting kit that includes a sheet metal bracket, mounting clamps and TEK screws. This includes directions for field mounting and adjustment. Desired head pressure should be maintained at approximately 340-400 PSIG for R-410A and 230-270 PSIG for R-407C.

Typical settings for the ambient thermostats are as follows:

Number of Fans	Header Fan	Fan 2	Fan 3	Fan 4	Fan 5
2	FSC	Pressure Control			
3	FSC	Pressure Control	75°		
4	FSC	Pressure Control	85°	75°	
5	FSC	Pressure Control	85°	75°	65°

4.6 Fluid Coolers - Model DAFC

4.6.1 Fluid-Sensing Thermostats

Fluid cooler fan motors are cycled on and off by individual water-sensing thermostats strapped to the leaving water header. The first fan motor will only have a thermostat if the unit has an Energy Saver Coil. Without the optional Energy Saver Coil, the first fan motor runs whenever there is a call for cooling via an auxiliary signal sent by the indoor evaporator (see Section 3.5).

The water-sensing thermostats have adjustable setpoints which are typically staggered to maintain water temperature in the 85° to 105° F range. This is generally the desired range for glycol cooled systems.

A surge tank is standard on all fluid coolers. This is sufficient on most applications. However, an expansion tank should be installed at the highest point in the system and the point of least pressure.

4.6.2 Energy Saver Cooling

In colder climates, the evaporator will often be equipped with an additional free cooling coil to take advantage of the colder ambient temperatures. When incoming fluid falls below the setpoint of a water-sensing thermostat in the evaporator (typically about 50° F), energy saver cooling becomes available.

Systems with an Energy Saver Coil should have at least one fluid-sensing thermostat on the fluid cooler set lower to take advantage of colder ambient temperatures. The desired fluid temperature for energy saver cooling is 45° F. Field adjustment of fluid-sensing thermostats is not unusual.

It is desirable to use the energy saver mode as much as possible. However, fluid temperature that is too cold can cause excessive dehumidification and coil sweating. Fluid temperature that is too high can also cause the indoor space temperature to rise. This could cause the evaporator's microprocessor control to lock out the energy saver mode for one hour while it reverts back to compressor (mechanical) cooling. Adjust the setpoints of the thermostats to allow the maximum free cooling time. Over cooling or under cooling the fluid should be avoided.



Every application will have a different ambient temperature and indoor heat load/air distribution profile. Therefore it is not possible to dictate the exact water-sensing thermostat setpoints. Field adjustments are typical to allow fine-tuning to specific conditions.

5.0 CHARGING

5.1 Voltage Phase Check

5.1.1 Evaporator

Prior to charging, the correct voltage phasing should be checked on the indoor evaporator. It is easiest to check the blower direction on the evaporator with standard poly-phase motors by momentarily moving the blower manual bypass switch located in the dap4 manual override module to the ON position, then back to the OFF position. Reverse any two of the three line voltage wires at the line voltage field connection point to change the blower rotation.

Although scroll compressors are phase dependent, units shipped from the factory are run tested, ensuring the compressor rotation is consistent with the evaporator fan motor. However, a field change-out of a compressor may require checking proper phase. An out-of-phase compressor will draw relatively low amps and both suction and discharge pressures will remain nearly equal.

5.1.2 Secondary Heat Exchanger

The secondary heat exchanger may be ordered as three phase but the individual fan motors are single phase and will only run in one direction. Check operation by placing a momentary jumper across low voltage field terminals # 30 and # 40. (Disconnect pumps on glycol systems unless already filled with water/glycol solution.) This will energize the control circuit. Fans may not turn because either the thermostat setpoint is above the current ambient temperature or the # 1 fan (on air cooled condensers with fan speed control) has not reacted to the head pressure. On systems with R-410A the fan will not operate until the head pressure is beyond 300 PSIG. Units with R-407C the head pressure must reach 200 PSIG.

5.2 Important Refrigeration Components

5.2.1 Expansion Valve

Each refrigerant circuit has an adjustable thermo-expansion valve (TXV). These are factory adjusted to their nominal rating. Any field adjustment should be to fine tune a system that has stabilized and already has acceptable operating parameters. Adjusting a TXV to produce large swings in superheat is not recommended.

5.2.2 High Pressure Cutout Switch

Each refrigerant circuit is protected by a high head pressure cutout switch with manual reset button. The switch is typically located in the evaporator near the compressors.

The pressure rating for R-410A is 610 PSIG. The pressure rating for R-407C is 400 PSIG.

5.2.3 Low Pressure Cutout Switch

Each refrigerant circuit has a low pressure cutout switch with automatic reset. The switch is located near the compressors.

The pressure rating for R-410A is 50 PSIG. The pressure rating for R-407C is 28 PSIG.

5.3 Air Cooled Systems

5.3.1 Fan Speed Control System Charging

The standard air cooled condenser provided with Data Aire equipment has fan speed control on the lead motor (nearest the header). After the field refrigerant piping is properly completed connect the refrigerant drum to the low side and charge with vapor. (Refer to Section 2.6 LEAK TESTING and Section 2.7 EVACUATION prior to charging the system.)

It is likely that more refrigerant will be required to complete the charging procedure (line runs need to be taken into account). Make sure all hoses are properly purged. From a vacuum feed liquid refrigerant into the high side of the system until the pressure equalizes. At this point there will be about 70-80% of the total charge in the system.

Before starting a compressor, the crankcase heater should be energized for a minimum of 12 hours to reduce the possibility of liquid slugging on start-up. Failure to energize the crankcase heater could result in compressor damage.

If the system is charged from a vacuum, the preheating of the compressor is not necessary. Start the system and allow the system to stabilize to room temperature. Bubbles in the sight glass are not unusual at this point and can be caused by flashing from liquid line pressure drop, low sub-cooling or low charge. It is likely that more refrigerant will be required to complete the charging procedure. Adjust the refrigerant charge until the sub-cooling is between 8 and 10°F. There may be flashing and/or bubbles in the sight glass when the system is properly charged.

The system should be allowed to stabilize for 15 to 20 minutes before meaningful measurements can be taken. After the system is allowed to stabilize, verification of a few key measurements should be noted. The discharge pressure with R-410A should be between 340-415 PSIG and the sub-cooling should be between 8-10°F depending on ambient conditions. Units with R-407C the discharge pressure should be between 240-295 PSIG. Suction temperature should be 100 PSIG or greater with R-410A and 58 PSIG or greater with R-407C. Measure the superheat at the compressor suction line at least 6 inches away from the compressor. The superheat should be between 8-15°F.

Note: Charging to a full liquid line sight glass should never be the sole means of determining the correct refrigerant charge. Other parameters such as superheat, suction pressure, head pressure, sub-cooling and ambient temperature are also important. A system charged to a clear sight glass is often overcharged.

5.3.2 Flooded System Charging

Flooded type systems are units having refrigerant circuits with an optional liquid receiver and head pressure control valve. When the ambient temperature falls during cold weather, the head pressure control valve will regulate the flow of refrigerant to ensure nearly constant receiver pressure. The condenser is partially flooded with liquid in cold weather. In warm weather the extra refrigerant is stored in the receiver.

Flooded systems require more refrigerant than fan speed control systems. Connect the pressure gauge manifold set to the high and low ports near the compressor. Connect the charging line to the refrigerant tank and set it for liquid feed. Open the refrigerant tank valve and purge the line.

Open the high side valve on the manifold only and allow the refrigerant to flow until the system pressure equalizes. At this point the system will have 78-85% of the total refrigerant charge. Start the (evaporator) motor(s). Start the compressor(s) and check the operating pressures and temperatures.

A quick and easy way to run the blower and compressor is using the manual switches on the unit's microprocessor. Switch the blower and compressor manual switches to the ON position. All automatic control is disabled but safety switches will remain functional.

Before starting a compressor, the crankcase heaters should be energized for a minimum of 12 hours to reduce the possibility of liquid slugging on start-up. Failure to energize crankcase heaters could result in compressor damage.

Start the evaporator fan and verify the fan rotation. From a vacuum, add liquid refrigerant to the high side of the system until the pressures equalize. Start the compressor. Check the liquid line sight glass to get a feel for the approximate charge. Bubbles in the sight glass are not unusual at this point and be caused by flashing from liquid pressure drop, low sub-cooling or low charge. It is likely that more refrigerant will be required to complete the charging procedure.

If the receiver (head) pressure is below 350 PSIG for R-410A, block part of the condenser coil surface until the pressure rises to 350 PSIG or higher. If the receiver (head) pressure is below 230 PSIG with R-407C, block part of the condenser coil surface until the pressure rises to 230 PSIG or higher. During extremely cold weather all the condenser fans have to be de-energized to maintain head pressure. Add refrigerant to the system until the ball in the sight-glass is at the 1/3 level.

After the system is allowed to stabilize, the superheat at the compressor suction line (reading from at least 6 inches from the sight glass) should be 8 – 15°F. Remove any blocks that may have been used on the condenser coil. If the ambient temperature is below 60°F, some of the refrigerant will be backed up in the condenser coil causing the liquid level in the receiver to drop (this is normal).

Note: Charging to a full liquid line sight glass should never be the sole means of determining the correct refrigerant charge. Other parameters such as superheat, suction pressure, head pressure, sub-cooling and ambient temperature are also important. A system charged to a clear sight glass is often overcharged.

5.4 Water/Glycol Cooled Systems

5.4.1 Water/Glycol Cooled Systems Charging

All water/glycol cooled units are factory charged with refrigerant. The water regulating valve should be adjusted to maintain a discharge pressure between 340–390 PSIG for R-410A and 230-260 for R-407C. Saturated suction pressure should be 100 PSIG or higher with R-410A and 58 PSIG or greater with R-407C. The superheat at the compressor suction line at least 6 inches away from compressor should be between 8-15°F.

Field charging water/glycol system should be done by referring to the unit electrical nameplate for factory charge. Although this figure represents the original factory charge, it is still necessary to measure and note proper unit operation including superheat, head and suction pressure. Some adjustment to charge may be required.

Adjust the refrigerant charge until the sight glass clears or has only sparse bubbles. The unit should be allowed to stabilize for several minutes before meaningful measurements can be taken and the conditioned room should be at or near the temperature setpoint.

All water/glycol cooled units have a water regulating valve. A head pressure transducer is connected to a schrader fitting on the discharge line and water is regulated into the condenser coil. Plate fin condensers are standard.

Before starting a compressor, the crankcase heaters should be energized for a minimum of 12 hours to reduce the possibility of liquid slugging on start-up. Failure to energize crankcase heaters could result in compressor damage.

Note: Charging to a full liquid line sight glass should never be the sole means of determining the correct refrigerant charge. Other parameters such as superheat, suction pressure, head pressure, sub-cooling and ambient temperature are also important. A system charged to a clear sight glass is often overcharged.

5.5 Refrigerant Handling

The use of recovery/recycling units is required by U.S. Environmental Protection Agency (EPA) regulations. Technicians who service and dispose of air conditioning and refrigeration equipment must recover the refrigerant instead of venting it to the atmosphere.

Except for extremely small releases of refrigerant such as what occurs when disconnecting service hoses (diminuous release), a technician who knowingly releases or vents refrigerant to the atmosphere is in violation of this regulation. Freon purchasers must be certified technicians and have a valid EPA certification card.

Warning! Pressure relief lines(s) must be vented to the atmosphere per the latest edition of ASHRAE Standard 15 and/or any local building, fire or mechanical codes.

This applies to all units with either sell and tube condensers or high pressure relief valve options.

6.0 GLYCOL SYSTEMS

6.1 Glycol Concentration

The system must be filled with water and the appropriate amount of ethylene or propylene glycol to protect against winter freeze-up. To achieve the approximate glycol concentration, it is necessary to know the total system volume. This consists of the sum of the fluid cooler volume, the evaporator unit volume, and the volume of the interconnecting piping.

The following tables can be used for arriving at an approximate system volume. After installation, the glycol percentage should be checked. The glycol percentage should also be checked at regular intervals to ensure freeze protection.

6.2 Internal (Fluid) Volume - Downflow Models

Evaporator Model	Without Energy Saver Coil Volume, Gallons	With Energy Saver Coil Volume, Gallons
DAGD 06	4.0	9.1
DAGD 08	4.5	9.6
DAGD 10	5.0	10.1
DAGD 13	5.5	10.6
DAGD 16	7.5	16.3
DAGD 20	8.0	16.8
DAGD 26	10.0	18.8
DAGD 30	12.0	22.9

6.3 Internal (Fluid) Volume - Upflow Models

Evaporator Model	Without Energy Saver Coil Volume, Gallons	With Energy Saver Coil Volume, Gallons
DAGU 06	4.0	8.2
DAGU 08	4.5	8.7
DAGU 10	5.0	9.2
DAGU 13	5.5	9.2
DAGU 16	7.5	15.9
DAGU 20	8.0	16.8
DAGU 26	10.0	16.3
DAGU 30	12.0	23.1

Note: Add 25% more for Shell and Tube condenser coils.

6.4 Fluid Cooler Internal Volume

Fluid Cooler Model	Internal Volume Volume, Gallons
DAFC 06	2.5
DAFC 07	3.4
DAFC 09	4.2
DAFC 11	3.3
DAFC 15	4.9
DAFC 17	6.6
DAFC 21	7.4
DAFC 24	9.8
DAFC 28	12.3
DAFC 30	9.8

Fluid Cooler Model	Internal Volume Volume, Gallons
DAFC 37	13.0
DAFC 40	16.3
DAFC 44	16.2
DAFC 50	20.3
DAFC 57	24.6
DAFC 61	19.6
DAFC 75	26.0
DAFC 80	32.6
DAFC 88	32.4
DAFC 100	40.6

6.5 Copper Piping Internal Volume

Pipe Diameter inches	Volume per 100 Feet of Pipe, Gallons
5/8	1.2
3/4	1.8
7/8	2.5
1-1/8	4.3
1-5/8	9.2
2-1/8	16.1
2-5/8	24.8
3-1/8	35.4
4-1/8	62.2

6.6 Freezing Point of Aqueous Solutions

Ethylene Glycol % by Volume	Freezing Point Degrees F	Propylene Glycol % by Volume	Freezing Point Degrees F
0	32	0	32
10	24	10	27
20	15	20	18
30	4	30	8
40	-13	40	-6
50	-33	50	-26

7.0 CONTROLS

7.1 *dap4* Microprocessor Control Panel

The standard controls on all *Data Aire Series* equipment is the *dap4* microprocessor control panel. This state-of-the-art control panel has a separate manual that goes into extensive detail regarding functions, features, programming, and troubleshooting.

The *dap4* microprocessor control panel has an entire manual dedicated to its use and operation. This manual must be referenced to complete a thorough unit installation. Start-up is not complete until the *dap4* control panel settings are established.

7.2 Secondary Heat Exchangers

Most of the controls on remote condensers, condensing units, and fluid coolers consist of basic electromechanical type components. Secondary heat exchangers have separate Selection Guide/ Operation and Maintenance manuals which give complete details on adjusting thermostat settings, etc. Refer also to details in Section 3.5 within this manual.

7.3 Wiring Diagrams

Every Data Aire evaporator, condenser, condensing unit, or fluid cooler comes with a wiring diagram. These diagrams are 'ladder'- type schematics intended for service personnel. The intent is to allow the technician to understand the wiring details associated with the electrical components and how they interface with the *dap4* control panel as well as peripheral equipment, including secondary heat exchangers.

The wiring diagram in the evaporator will indicate field interface terminals to the secondary heat exchanger. The internal wiring of the heat exchanger is found on a separate diagram which can be found on the inside cover of the heat exchanger electrical box. Both diagram types are also placed inside the shipping/warranty packet that is placed inside the evaporator.

Evaporator wiring diagrams will have a drawing number which starts out with the three letter designation, "DAX". An example of a typical diagram is DAX-S-603 N. Wiring diagrams for condensers or condensing units start out with the three letter designation, "DRC". An example of a typical diagram is DRC-S-001. Wiring diagrams for fluid coolers start out with the three letter designation, "DFC". An example of a typical diagram is DFC-S-001.

8.0 REGULAR MAINTENANCE ITEMS

8.1 Filters

Filters should be checked on a regular basis and changed when they become dirty. This will ensure efficient operation of the unit. Although the unit has a dirty filter alarm, this should not be relied on as the only determinant for replacing filters. A maladjusted filter differential pressure switch may not give a proper indication of a clogged filter.

To check the filter differential pressure switch for proper adjustment, temporarily cover about 75% of the return air opening using heavy cardboard or similar material. The alarm should energize when 75% of the air is blocked, simulating dirty filters. If the alarm energizes prematurely or does not energize at all, the pressure switch should be adjusted. Doors must remain closed when determining if an adjustment is necessary.

Spare filters should be kept in stock as these tend to be a frequently replaced maintenance item. Filters may require changing as often as monthly. Note also that construction dust on new installations will quickly clog new filters.

Filters that require changing can restrict airflow and create problems such as coil icing or poor air distribution.

8.2 Belts

Belt tension should be checked regularly (monthly) to ensure proper tension. If tightening is required, loosen the four motor mounting bolts. Turn the adjustment screw on the end of the motor mounting channel until the proper belt tension is attained. Retighten the four mounting bolts. Damage can also occur to belts that are overtightened. The amount of play in a typical drive set should be 1/2 inch.

8.3 Bearings

Pillow block bearings used on many models have zerk type grease fittings. These will require grease at least annually - use NLGI grade 2 lithium or lithium complex grease. Care should be taken to avoid over-greasing. Only one or two pumps from a manual gun are required. All other blower bearings are permanently lubricated and do not require maintenance.

On units having sealed type ball bearings with clamps on collars or retaining rings, proper torque for collar or retaining rings is 65-70 in-lbs. Ensure that collars or retaining rings are perpendicular to the shaft, if they are not perpendicular damage to the blower shaft will occur.

Most blower motors have sealed bearings and are maintenance free. Some motors have zirk type grease fittings on the bearings. If so the motor should be greased once annually. Care should be taken to avoid over-greasing. Only one or two pumps from a manual gun are required.

8.4 Humidifier Canisters

Steam generator type humidifier is standard on *Data Aire Series* equipment. There is no maintenance required other than to replace the canister as required. This frequency will depend on usage and water type. A set of manufacturer's instructions for the humidifier is sent as part of the paperwork placed inside the unit when it ships.

8.5 Fuses

Fuses will occasionally require changing especially with installations where the voltage is not consistent. Drops in voltage can create brief periods of high amp draw, causing fuses to blow. Always replace fuses with those of the equivalent rating with regard to: 1) amperage, 2) voltage, and 3) speed. For instance compressors and motors are inductive loads which require time delay fuses. Electric reheat and humidifiers are resistive loads requiring fast acting fuses.

8.6 Heating Elements

Heating elements do not normally require maintenance. However sometimes they may accumulate a film of dust or dirt when unused for extended periods of time. When energized, the burning debris can create smoke or unpleasant odor. To help avoid this, periodic cleaning is recommended.

8.7 Refrigerant Filter Drier

Factory installed refrigerant filter driers do not normally require maintenance. When replacing compressors or other repairs that open the refrigeration system to atmosphere, it is advisable to replace the filter drier. The equivalent type and size should be used.

9.0 Warranty Policy

Data Aire Inc. warrants your Data Aire environmental control unit to be free from defects in material and workmanship under normal use and service for a period of (18) eighteen months from date of shipment. Our obligation under this warranty shall be limited to repairing or replacing any part or parts, (F.O.B. Orange, California), of your Data Aire unit, which, in our judgment, shows evidence of defect within the period of time heretofore set forth. Upon our request, the said part(s) shall be returned to Data Aire Inc. at Orange, California, transportation charges prepaid. LABOR is not covered by this warranty.

ADDITIONAL MOTOR-COMPRESSOR LIMITED WARRANTY: Data Aire Inc. offers for sale additional motor-compressor limited warranties, which warrants the motor-compressor to be free from defective material or workmanship under normal use and service for an additional period as indicated above immediately following the expiration of the STANDARD LIMITED WARRANTY and will repair or replace (F.O.B. Orange, California) the motor-compressor found by it to have become inoperative due to defects in material or workmanship, provided that inspection by Data Aire Inc. established the validity of the claim.

The ADDITIONAL MOTOR-COMPRESSOR LIMITED WARRANTY does not include such parts as the cabinet, electrical components and controls, refrigerant, refrigerant tubing, expansion valve(s), pressure relief device, fan motor, filters, water regulating valve(s), if used, or any parts other than the motor-compressor. Failure(s) due to the condition of the water supply or failure due to the entry of water to the motor-compressor as a result of a freeze-up are also excluded.

These warranties cannot be transferred or assigned by you and shall run only in favor of the original owner-user of the Data Aire Inc. unit.

Prior written authorization by Data Aire, Inc. is required for the return of any parts, which are deemed to be defective.

These warranties shall not apply to the replacement of air filters, belts, refrigerant, customer provided parts, heaters not regularly cleaned, correction or conditions due to inadequate or improper air or water supply, improper or incorrectly connected duct work, inadequate wiring, power supply, blown fuses, humidifier cylinders, light bulbs and infrared lamps, or if, in our judgment, your Data Aire Inc. unit has been subjected to misuse, negligence, accidental damage caused in transit, damage caused by lack of protection from extreme environmental conditions, tampering, alteration in any way, or if the serial number has been abused, altered, defaced, or removed. Additionally, these warranties shall not apply, if in the judgment of Data Aire Inc., the unit has not been serviced and maintained regularly in accordance with established maintenance procedures.

Parts that are project specific and deemed special (non-Data Aire catalog items) which are installed and provided by Data Aire Inc. shall be subject to Data Aire's vendor's standard warranty. Data Aire will not stock or maintain inventory on such parts. Replacement of project specific parts will be subject to vendor's standard lead times.

Data Aire Inc. shall not be liable for any default or delay in performance under these warranties when caused by any contingencies beyond our control, including war, government restrictions or restraints, strikes, fires, floods, acts of nature or inadequate raw material supplies.

Except as stated above, Data Aire Inc. makes no warranty or guarantee, expressed or implied.

10.0 Contact Data Aire

Address:

Data Aire, Inc.
230 W. BlueRidge Avenue
Orange, CA 92865

Phone

714-921-6000
800-347-AIRE (2473) Toll Free

Fax:

714-921-6010 Main
714-921-6011 Engineering
714-921-6022 Part Sales

E-mail:

service@dataaire.com Technical Support
engineering@dataaire.com Engineering
sales@dataaire.com Sales

Web site:

www.dataaire.com

Job information:

Evaporator

Model Number: DA ___ - _____ - ____

Serial Number: _____ - _____ - ____

Condenser/Fluid Cooler:

Model Number: D _____ - ____

Serial Number: _____ - _____ - ____

Job number: _____

Date installed: ___ / ___ / 20___

Installing Contractor: _____

RECOMMENDED LINE SIZING FOR AIR COOLED SPLIT SYSTEMS UP TO 200 EQUIVALENT FEET

HOT GAS LINES											
SINGLE CIRCUIT SYSTEMS				DUAL CIRCUIT SYSTEMS							
Unit Tonnage	Tons per Circuit	EQUIVALENT FEET				Unit Tonnage	Tons per Circuit	EQUIVALENT FEET			
		50	100	150	200			50	100	150	200
1	1	5/8	5/8	5/8	7/8	6	3	7/8	7/8	7/8	7/8
1.5	1.5	5/8	5/8	7/8	7/8	8	4	7/8	7/8	7/8	1-1/8
2	2	5/8	7/8	7/8	7/8	10	5	7/8	1-1/8	1-1/8	1-1/8
2.5	2.5	5/8	7/8	7/8	7/8	13	6.5	7/8	1-1/8	1-1/8	1-1/8
3	3	7/8	7/8	7/8	7/8	16	8	1-1/8	1-1/8	1-3/8	1-3/8
4	4	7/8	7/8	7/8	1-1/8	20	10	1-1/8	1-1/8	1-3/8	1-3/8
5	5	7/8	1-1/8	1-1/8	1-1/8	26	13	1-1/8	1-3/8	1-3/8	1-3/8
6	6	7/8	1-1/8	1-1/8	1-1/8	30	15	1-3/8	1-3/8	1-3/8	1-5/8
8	8	1-1/8	1-1/8	1-3/8	1-3/8						
10	10	1-1/8	1-1/8	1-3/8	1-3/8						
13	13	1-1/8	1-3/8	1-3/8	1-3/8						

LIQUID LINES											
SINGLE CIRCUIT SYSTEMS				DUAL CIRCUIT SYSTEMS							
Unit Tonnage	Tons per Circuit	EQUIVALENT FEET				Unit Tonnage	Tons per Circuit	EQUIVALENT FEET			
		50	100	150	200			50	100	150	200
1	1	3/8	3/8	3/8	3/8	6	3	1/2	1/2	1/2	1/2
1.5	1.5	3/8	3/8	3/8	3/8	8	4	1/2	5/8	5/8	5/8
2	2	3/8	1/2	1/2	1/2	10	5	1/2	5/8	5/8	5/8
2.5	2.5	3/8	1/2	1/2	1/2	13	6.5	1/2	5/8	5/8	5/8
3	3	1/2	1/2	1/2	1/2	16	8	5/8	7/8	7/8	7/8
4	4	1/2	5/8	5/8	5/8	20	10	5/8	7/8	7/8	7/8
5	5	1/2	5/8	5/8	5/8	26	13	7/8	7/8	7/8	7/8
6	6	1/2	5/8	5/8	5/8	30	15	7/8	7/8	7/8	7/8
8	8	5/8	7/8	7/8	7/8						
10	10	5/8	7/8	7/8	7/8						
13	13	7/8	7/8	7/8	7/8						

SUCTION LINES										
SINGLE CIRCUIT SYSTEMS										
Unit Tonnage	Tons per Circuit	EQUIVALENT FEET								
		50		100		150		200		
		HOR	VER	HOR	VER	HOR	VER	HOR	VER	
1	1	7/8	7/8	7/8	7/8	7/8	7/8	7/8	7/8	7/8
1.5	1.5	7/8	7/8	7/8	7/8	7/8	7/8	7/8	7/8	7/8
2	2	7/8	7/8	7/8	7/8	7/8	7/8	1-1/8	7/8	7/8
2.5	2.5	7/8	7/8	7/8	7/8	7/8	7/8	1-1/8	7/8	7/8
3	3	7/8	7/8	1-1/8	7/8	1-1/8	7/8	1-1/8	7/8	7/8
4	4	1-1/8	1-1/8	1-1/8	1-1/8	1-1/8	1-1/8	1-3/8	1-1/8	1-1/8
5	5	1-1/8	1-1/8	1-1/8	1-1/8	1-3/8	1-1/8	1-3/8	1-3/8	1-1/8
6	6	1-1/8	1-1/8	1-3/8	1-1/8	1-3/8	1-1/8	1-3/8	1-5/8	1-3/8
8	8	1-3/8	1-3/8	1-3/8	1-3/8	1-3/8	1-3/8	1-5/8	1-3/8	1-3/8
10	10	1-3/8	1-3/8	1-5/8	1-3/8	1-5/8	1-5/8	1-5/8	1-5/8	1-5/8
13	13	1-3/8	1-3/8	1-5/8	1-5/8	1-5/8	1-5/8	2-1/8	1-5/8	1-5/8

DUAL CIRCUIT SYSTEMS										
Unit Tonnage	Tons per Circuit	EQUIVALENT FEET								
		50		100		150		200		
		HOR	VER	HOR	VER	HOR	VER	HOR	VER	
6	3	7/8	7/8	1-1/8	7/8	1-1/8	7/8	1-1/8	7/8	7/8
8	4	1-1/8	1-1/8	1-1/8	1-1/8	1-1/8	1-1/8	1-3/8	1-1/8	1-1/8
10	5	1-1/8	1-1/8	1-1/8	1-1/8	1-3/8	1-1/8	1-3/8	1-1/8	1-1/8
13	6.5	1-1/8	1-1/8	1-3/8	1-1/8	1-3/8	1-1/8	1-5/8	1-3/8	1-3/8
16	8	1-3/8	1-3/8	1-3/8	1-3/8	1-3/8	1-3/8	1-5/8	1-3/8	1-3/8
20	10	1-3/8	1-3/8	1-5/8	1-3/8	1-5/8	1-5/8	1-5/8	1-5/8	1-5/8
26	13	1-3/8	1-3/8	1-5/8	1-5/8	1-5/8	1-5/8	2-1/8	1-5/8	1-5/8
30	15	1-5/8	1-3/8	1-5/8	1-5/8	2-1/8	1-5/8	2-1/8	1-5/8	1-5/8

HOR = HORIZONTAL
VERT = VERTICAL

Data Aire, Inc.

Monthly Maintenance Inspection Checklist

Model No. _____
Prepared by: _____

Serial No. _____
Date: ___ / ___ / 20___

Air Filters

___ Check for restricted air flow

___ Check canister for deposits and water level
___ Check condition of steam hose and clamps

Blower Section

___ Blower wheel free of debris moves freely
___ Check belt tension and condition
___ Bearings in good condition
___ Check pulleys and motor mounts

Infrared Humidifier (if applicable)

___ Check humidifier lamps
___ Check pan for mineral deposits

Air Distribution Section

___ Check for restriction in grille(s)

Electrical Panel

___ Check contactor operation
___ dap4 control panel operations

Compressor

___ Check oil levels (Semi-compressor only)
___ Check for leaks

Equipment Runtimes

Blower	_____	hrs
Condenser	_____	hrs
Compressor No.1	_____	hrs
Compressor No. 2	_____	hrs
Reheat No. 1	_____	hrs
Reheat No. 2	_____	hrs
Reheat No. 3	_____	hrs
Humidifier	_____	hrs
Dehumidification	_____	hrs
Energy Saver	_____	hrs

Refrigeration Cycle/Section

___ Check crank case temperature

___ Reset all to read zero runtimes

Air Cooled Condenser (if applicable)

___ Condenser coil clean
___ Motor mounts tight
___ Motor fan bearings in good condition
___ Refrigeration lines properly supported

Temperature/Humidity set at: ___ ° ___ % RH

Water/Glycol Fluid Cooler (if applicable)

___ Water regulating valve function
___ Check for water/glycol leaks (piping area)

Notes: _____

Glycol Pump(s)

___ Glycol leaks (pump area)
___ Pump operation
___ Auto air vent clean of mineral deposits

Condensate Drain and Pump (if applicable)

___ Check for water leaks
___ Check for restricted air flow
___ Pump operation

Steam Generating Humidifier

Data Aire, Inc.

Quarterly Maintenance Inspection Checklist

Model No. _____
 Prepared by: _____

Serial No. _____
 Date: ___ / ___ / 201__

Air Filters

- Check for restricted air flow
- Check filter differential switch
- Wipe filter rack section clean

Blower Section

- Blower wheel free of debris and moves freely
- Check belt tension and condition
- Bearings in good condition
- Check air flow safety switch operation
- Check pulleys and motor mounts

Air Distribution Section

- Check for restriction in grille(s)

Compressor

- Check oil levels (Semi-hermetic compressor only)
- Check for leaks

Refrigeration Cycle/Section

- Check for moisture (site glass)
- Check suction pressure
- Check discharge pressure
- Check hot gas bypass valve operation
- Check thermostatic expansion valve op
- Check solenoid valve operation

Air Cooled Condenser (if applicable)

- Condenser coil clean
- Motor mounts tight
- Motor fan bearings in good condition
- Refrigeration lines properly supported
- Heated receiver site glass #1 ___ #2 ___

Water/Glycol Fluid Cooler (if applicable)

- Water regulating valve function
- Check solution _____%
- Check for water/glycol leaks (piping area)
- Water/Glycol flow switch operational

Glycol Pump(s)

- Glycol leaks (pump area)
- Pump operation
- Auto air vent clean of mineral deposits

Condensate Drain and Pump (if applicable)

- Check for water leaks and restricted flow
- Pump operation

Steam Generating Humidifier

- Check canister for deposits and water level
- Check condition of steam hose and clamps
- Check drain and fill valve for deposits

Infrared Humidifier (if applicable)

- Check humidifier lamps
- Check pan for mineral deposits
- Check high limit switch operation
- Check drain timer operation
- Check drain valve operation

Reheat

- Check reheat element(s) for dust
- Check high limit switch operation

Electrical Panel

- Check fuses
- Check contactor operation
- Check all electrical connections
- Check operation sequence
- Check calibration of change over thermostat (Energy Saver System Only)

Equipment Runtimes

Blower	_____	hrs
Condenser	_____	hrs
Compressor No. 1	_____	hrs
Compressor No. 2	_____	hrs
Reheat No. 1	_____	hrs
Reheat No. 2	_____	hrs
Reheat No. 3	_____	hrs
Humidifier	_____	hrs
Dehumidification	_____	hrs
Energy Saver	_____	hrs

Reset all to read zero runtimes

Temperature/Humidity set at: _____° _____% RH

Notes: _____

Superheat and Suction Pressure Trouble Shooting Guide

Low Suction Pressure and High Superheat

1. Moisture, dirt, wax
2. Undersized valve*
3. High superheat adjustment
4. Gas charge condensation
5. Dead thermostatic element charge
6. Wrong thermostatic charge
7. Evaporator pressure drop - no external equalizer
8. External equalizer location
9. Restricted or capped external equalizer
10. Low refrigerant charge
11. Liquid line vapor
 - a. Vertical lift
 - b. High friction loss
 - c. Long or small line
 - d. Plugged drier or strainer
12. Low pressure drop across valve
 - a. Same as #11 above
 - b. Undersized distributor nozzle or circuits
 - c. Low condensing temperature

High Suction Pressure - Low Superheat

1. Oversized valve*
2. TEV seat leak
3. Low superheat adjustment
4. Bulb installation
 - a. Poor thermal contact
 - b. Warm location
5. Wrong thermostatic charge
6. Bad compressor - low capacity
7. Moisture, dirt, wax
8. Incorrectly located external equalizer

Low Suction Pressure - Low Superheat

1. Low load
 - a. Not enough air
 - b. Dirty air filters
 - c. Coil icing
2. Poor air distribution
3. Poor refrigerant distribution
4. Improper compressor-evaporator balance
5. Evaporator oil logged
6. Flow from one TEV affecting another's bulb

* Data Aire has ensured that valves are size properly as the unit ships from the factory.

- A -

Air Cooled Systems9, 10, 18-22
 Air Filters28
 Air Vents 11
 Ambient Thermostats 19
 Auxiliary Wiring 16

- B -

Bearings28
 Belts28

- C -

Cable, Water Sensing 18
 Charging 21
 Air Cooled Fan Speed Systems ..22
 Air Cooled Flooded Systems22
 Water/Glycol Systems23
 Coils
 Auxiliary Chilled Water25
 Condenser25
 Evaporator25
 Fluid Cooler25-6
 Volume see Volume

Compressors
 Crankcase Heaters22, 23
 Manual Bypass/Override21, 22

Condensate Cable 17
 Condensate Probe 18
 Condensate Pumps 18
 Condensers 10, 15, 18-22, 27
 Condensing Units 10,15,18-22, 27

Connection Sizes
 Air Cooled Units9
 Fluid Coolers 12
 Water/Glycol Cooled Units 12

Contact Data Aire 31
 Controls27
 dap4 Control Panel27
 Secondary Heat Exchangers27
 Wiring Diagrams27

Crankcase Heaters22, 23

- D -

dap4 Control Panel27
 Differential Pressure Switch28
 Discharge Lines9, 10, 32
 Disconnect Switch 6

INDEX

- E -

Electrical 15
 Evaporator..... 16
 Energy Saver20
 Expansion Valve21
 Expansion Tank 13
 Evaporator6-13, 15, 22-23

- F -

Fan Speed Control Systems..... 19, 21
 Field Piping.....9, 32
 Air Cooled 9, 10, 11, 32
 Auxiliary Chilled Water 13
 Condensate..... 13
 Condenser..... 9, 10, 11, 32
 Condensing Unit..... 11
 Dry Steam Humidifier..... 13
 Fluid Cooler..... 12
 Glycol Cooled..... 11, 25, 26
 Steam Generator Humidifier 13
 Water Cooled 13
 Field Wiring..... 15-17, 21
 Remote Alarm Contacts 17
 Remote Condenser 15, 21
 Remote Condensing Unit 15
 Remote Fluid Cooler 15, 21
 Remote Sensors 18
 Remote Shutdown..... 17

Filter
 Air.....28
 Drier29
 Differential Pressure Switch28

Flooded Systems..... 10, 22
 Floorstands.....7
 Flow Switch 11
 Fluid Coolers ... 11, 12, 15, 18, 21, 23, 25
 Fluid Sensing Thermostats.....20
 Freezing Point, Aqueous Solutions.....26
 Fuses.....29

- G -

Glycol Concentration24
 Glycol Systems
 12, 16, 19, 20, 22, 23, 24
 Grounding 15

- H -

Head Pressure24-24
 Control Valve.....23
 Cutout Switch.....21
 Water Regulating Valve.....24

Heat

Crankcase 22, 23
 Electric 29
 Reheat Elements..... 29
 High Pressure Cutout Switch..... 21
 Humidifier 13, 28
 Canister..... 28
 Dry Steam Humidifier 13
 Steam Generator Humidifier 13, 28

- I -

Inspection 6
 Installation 6-8, 18, 19
 Internal Volume see Volume

- J -

Jackstands..... 7

- L -

Liquid Lines 10, 11, 32
 Leak Testing 14
 Locating 7, 18
 Evaporator..... 7
 Secondary Heat Exchanger 18

- M -

Maintenance 28
 Bearings..... 28
 Belts 28
 Filters 28
 Fuses 29
 Heating Elements..... 29
 Humidifier Canisters..... 28
 Refrigerant Filter Drier..... 29

- P -

Paperwork 8
 Piping See *Field Piping*
 Probe, Condensate..... 17, 18
 Pumps
 Centrifugal..... 12
 Condensate..... 13

- R -

Receivers..... 23
 Recovery 24
 Refrigerant..... 21-24
 Charge see *Charging*
 Handling..... 24
 Recovery 24
 Reheat
 Elements 29
 Electric 29

Remote

Alarm Contacts..... 16
 Condensers..... 10, 15, 19-23, 27
 Condensing Units. 10, 15, 19-23, 27
 Fluid Coolers..... 12, 15, 18, 20, 24, 26
 Sensors..... 16
 Remote Shutdown..... 13

Rigging 6, 18

- S -

Secondary Heat Exchange

..... 10-12, 15, 21-24, 25, 27
 Sight Glass 22, 23
 Strainer 11
 Subcooling..... 22, 23
 Suction Lines 9, 10, 32
 Superheat..... 22-24

- T -

Thermo-expansion Valve (TXV) 21
 Thermostats
 Ambient..... 19, 20
 Fluid Sensing 20

Traps 10, 11

- V -

Valves

Head Pressure Control..... 22
 Humidifier Makeup Water..... 14
 Shutoff..... 11
 Water Regulating 24
 Voltage..... 15, 19, 21
 Phase Check..... 21

Volume

Copper Piping 26
 Fluid Coolers..... 25, 26
 Internal Fluid, Downflow..... 25
 Internal Fluid, Upflow 25

- W -

Warranty 30
 Water Sensing Cable..... 18
 Water Sensing Probe 18
 Wiring 15, 16, 21

- Z -

Zirk Fittings 28

Data Aire Series

*Air and Water/Glycol Cooled
DX 6-30 ton*

Installation, Operation & Maintenance Manual



Data Aire, Inc. | 230 W. BlueRidge Avenue | Orange, CA 92865 | www.dataaire.com

ISO 9001-2008 Certified | ©Copyright 2017 Data Aire, Inc. | A member of the CS Group of Companies | Making Products That Make Building Better

DASeriesDX 07/2019