

Data Cool™

*Air, Water and Glycol Cooled DX and Chilled Water
2 and 3 Ton*

Installation, Operation & Maintenance Manual



Data Aire, Inc.

230 W. BlueRidge Avenue

Orange, CA 92865

www.dataaire.com



CONGRATULATIONS ON THE SELECTION OF A DATA AIRE PRECISION ENVIRONMENTAL CONTROL SYSTEM. PROPER INSTALLATION, OPERATION AND MAINTENANCE OF THIS EQUIPMENT WILL ENSURE YEARS OF OPTIMAL PERFORMANCE.



This manual is intended to assist trained service personnel by providing necessary guidelines for this particular equipment. Installation and service to Data Aire units should be done by qualified individuals with an adequate background in areas such as HVAC, electrical, plumbing and electronics, as applicable.



Service performed by unauthorized or unqualified technicians may void manufacturers' warranties and could result in property damage and/or personal injury.



Special care should be given to those areas where these symbols appear.

Data Aire, Inc. reserves the right to make design changes for the purposes of product improvement, or to withdraw any design without notice.

Table of Contents

1.0	PRODUCT INTRODUCTION	5
1.1	Inspection	5
1.2	Controls	5
1.3	Evaporator Section	5
1.4	Outdoor Condensing Unit	5
1.5	Indoor Condensing Unit	6
1.6	Remote Water/Glycol Cooled Condensing Units	6
1.7	Model Identification	6
2.0	INSTALLATION	7
2.1	Room Considerations	7
2.2	Inspection	7
2.3	Locating the Unit	7
2.3.1	Indoor Condensing Unit	8
2.4	Leveling Legs	8
2.5	Paperwork	8
2.6	Storage	8
3.0	PIPING	9
3.1	Split Air Cooled Unit Piping	9
3.1.1	Liquid Lines	9
3.1.2	Suction Lines	9
3.1.3	Connection Sizes, Air Cooled Units	10
3.1.4	Field Piping, Remote Condenser/ Condensing Unit Above Evaporator	10
3.1.5	Field Piping, Remote Condenser/ Condensing Unit Below Evaporator	11
3.2	Water/Glycol Cooled Unit Piping	12
3.2.1	Connection Sizes, Water/Glycol Cooled Units	13
3.2.2	Connection Sizes, Fluid Coolers	13
3.3	Chilled Water Piping	14
3.4	Condensate Drain Piping	14
3.5	Humidifier Piping	15
3.6	Leak Testing	15
3.7	Evacuation	15
4.0	ELECTRICAL CONNECTIONS	16
4.1	Electrical Service	16
4.2	Nameplate Ratings	16
4.3	Grounding	16
4.4	Voltage Tolerance	16
4.5	Auxiliary Control Wiring	17

Table of Contents, continued

5.0	INSTALLATION OF REMOTE OUTDOOR HEAT EXCHANGER	17
6.0	CHARGING	18
6.1	Voltage Phase Check	18
6.1.1	Evaporator	18
6.1.2	Secondary Heat Exchanger	18
6.2	Air Cooled Systems	18
6.2.1	Split Indoor Air Cooled Systems Charging	18
6.2.2	Fan Speed Control System Charging	19
6.3	Water/Glycol Cooled Systems	20
6.3.1	Water/Glycol Cooled Systems Charging	20
6.4	Refrigerant Handling	21
6.5	Important Refrigeration Components	21
6.5.1	Expansion Valve	21
6.5.2	High Pressure Cutout Switch	21
6.5.3	Low Pressure Cutout Switch	21
7.0	CONTROLS	21
7.1	Standard Thermostat	21
7.2	Optional Programmable Thermostat	22
7.3	Optional Mini DAP II Microprocessor Control Panel	22
7.4	Optional DAP II Microprocessor Control Panel	22
7.5	Wiring Diagrams	22
8.0	REGULAR MAINTENANCE ITEMS	23
8.1	Air Filters	23
8.2	Bearings	23
8.3	Humidifier Canisters	23
8.4	Fuses	23
8.5	Heating Elements	23
8.6	Refrigerant Filter Drier	23
9.0	CONTACT DATA AIRE	24
	Line Sizing Chart	25
	Monthly Maintenance Inspection Checklist	26
	Quarterly Maintenance Inspection Checklist	27

1.0 PRODUCT INTRODUCTION

The Data Aire Data Cool is designed for environments where close temperature and humidity control is required. The unit is available as an air-cooled split system with either an outdoor or indoor condensing unit. The evaporator section is installed in the controlled environment against a wall. The Data Cool system has single stage cooling for temperature control.

1.1 Inspection

This Data Aire unit has been factory run tested and has gone through a comprehensive inspection prior to its packaging and shipment to ensure that it arrives in excellent condition. However, shipping damage can occur and a visual inspection of the outer crating immediately upon delivery should be performed.

Any external damage or other transportation damage should be noted on the freight carrier's delivery slip. Inspect the unit itself for internal damage. A claim should be filed with the shipping company if the equipment is damaged or incomplete.

Loose items such as remote control panels, disconnect switch handles and spare filters are packed inside the unit. Refer to the yellow shipping tag located on the unit door for details.

Freight damage claims are the responsibility of the purchaser. Action to recover losses should be filed immediately with the freight company. Refer to yellow shipping tag located on the unit door for details

1.2 Controls

Each Data Cool unit is shipped with a digital cooling only thermostat.

For spaces requiring precision control, an optional microprocessor control that automatically switches functions (cooling, reheat, humidification and dehumidification) based on programmed setpoint and room requirements. The Mini dap4 is a microprocessor based control that not only monitors the controlled environment's humidity, air flow and cleanliness, but also provides alarm history and an automatic self-test of the microprocessor on system start-up.

1.3 Evaporator Section

The evaporator section includes the evaporator coil, thermostatic expansion valve and blower assembly. The evaporator coil is constructed of copper tubes and aluminum fins. A stainless steel drain pan is standard on all Data Cool units.

The blower assembly consists of double-inlet, direct-drive centrifugal blowers that have been dynamically balanced. The motor has self-lubricating bearings. Air is drawn through the return air grille at the front of the unit and discharged from the top discharge grille. Filter access is through the front panel. Data Cool units include a high and low speed air delivery.

Field piping and wiring is required between the evaporator and condensing sections. The evaporator section requires a power source and disconnect switch.

1.4 Outdoor Condensing Unit

The condensing unit contains a scroll compressor with crankcase heater, filter drier, sight glass and condenser coil. The condenser coil is constructed of copper tubes and aluminum fins. The housing is constructed of aluminum. Air discharge is vertical. The condenser fan motor is thermally protected.

Field piping and wiring is required between the evaporator and condensing section. The condensing section requires a power source and disconnect switch.

1.5 Indoor Condensing Unit

The condensing unit contains a scroll compressor with crankcase heater, filter drier, sight glass and condenser coil. The condenser coil is constructed with copper tubes and aluminum fins. The condenser blower is a centrifugal type with double inlet, double width with belt drive and variable pitch sheave. A stainless steel drain pan is standard.

Field piping and wiring is required between the evaporator and condensing section. The condensing section requires a power source and disconnect switch.

1.6 Remote Water/Glycol Cooled Condensing Units

The remote, ceiling mounted condensing unit includes a scroll compressor with crankcase heater, filter drier, sight glass, plate/fin heat exchanger and head pressure water regulating valve. Maximum water pressure is 150 PSI. The condensing section requires a power source and disconnect switch.

Field piping and wiring is required between the evaporator and condensing section. A dry cooler (fluid cooler) or water-cooling source is required.

1.7 Model Identification

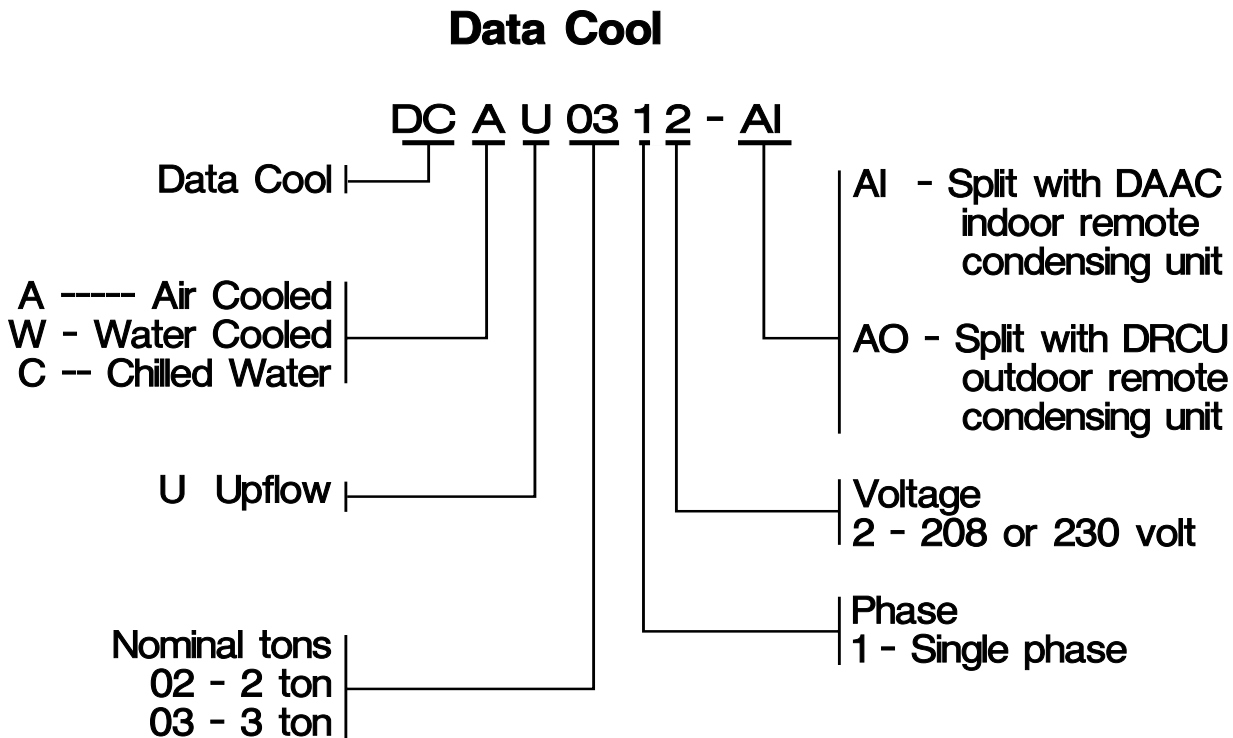

2.0 INSTALLATION



There is no intent on the part of Data Aire, Inc. to define local codes or statutes which may supercede common trade practices. The manufacturer assumes no responsibility for their interpretation. Consult local building codes and the National Electrical Code for special installation requirements.

2.1 Room Considerations

Precision air conditioning equipment is designed to control spaces within close tolerances of temperature and humidity. However, the room must be built with a proper vapor barrier. A film of polyethylene is often used on walls and ceilings. Walls and floors must also be painted with a vapor-seal paint. All doors to the data room should be equipped with weather seals to prevent the infiltration of non-neutral conditioned air from entering the data room. Failure to provide a vapor barrier can compromise the ability to control space conditions.

Introduction of outside air into the space should be minimized. Outside air in excess of 5% of the total circulated air volume can have a significant effect on the overall space conditions and result in poor space control. All outside air that is introduced into the space should be conditioned to the humidity and temperature parameters of the computer room air conditioning (CRAC) unit set points to maintain proper room conditions and to prevent the CRAC units from running excessively to maintain the room conditions.

2.2 Locating the Unit

When installing the unit, sufficient space must be allowed for airflow clearance, wiring, plumbing and service access. It is recommended that the left side have at least 36" of clearance and the front and right side have at least 18" of clearance to allow servicing of the unit.

Some sides may not require as much service clearance. Refer to the unit component drawings for assistance. Rear clearance is not required.



Note to Installing Contractor: Condensation formation and frequent humidifier flushing (when humidifier is installed) are normal functions of this equipment. Drain connections must be made to ensure proper water removal. Unit will require drain connections for condensate removal and water connections possibly for humidifier (when installed) makeup water, chilled water and/or hot water. Installation of units above equipment that could sustain water damage should be avoided.

2.3.1 Indoor Condensing Units

These 24" tall section is to be mounted using four threaded rods. Air cooled condensing units have factory provided duct collars on the supply and intake air openings as appropriate. Split water cooled condensing sections do not require airflow connections.

Typical installations have the condensing section physically near the evaporator, especially since most have shared electrical line power.

2.4 Leveling Legs

Each Data Cool comes equipped with four leveling legs. When mounting the unit on the floor, to ensure the best possible operation the leveling legs should be adjusted so that the unit is level.

2.5 Paperwork

Each Data Aire unit ships with a start-up sheet that must be completed during installation, and start up of the unit(s). Also included in the paperwork is a warranty/information packet that provides important wiring diagrams, specific component literature, warranty registration card and other valuable paperwork, including a copy of this Installation/Operation and Maintenance manual.

A manila tag is attached to the outside panel to indicate articles that may have been packaged and shipped loose within the unit cabinet. This could be the thermostat or other optional control devices that are not factory mounted.

It is the responsibility of the installing contractor to return the start-up sheet and warranty registration card to Data Aire for proper activation of the unit warranty. Failure to do so may cause delays in warranty related services and in some cases void the warranty.

2.6 Storage

Your Data Aire equipment comes ready for immediate installation. In some instances it may be necessary to store the equipment for a period of time. If you must store the equipment it should be done in a dry area, out of the weather, protected from freezing temperatures, protected from damage by other equipment in storage or transportation equipment, never stacked, and avoid frequent relocation.

If equipment is stored for longer than 30 days special precautions must be taken to avoid coil damage. All coils should be charged and sealed at the factory with a low pressure (less than 25 psig) inert gas, such as nitrogen. This prevents contaminants from entering the coils; then when the seal is broken at installation, the rush of escaping gas verifies the coil is still leak free. If coils are not charged and sealed condensation mixes with air pollutants forming a weak acid and can cause pin hole leaks to develop in the coil tubes.

When equipment is installed after storage caution should be taken to inspect and replace, if required, rubber hoses. All moving parts, such as blowers and motors, should be hand tested to ensure that they are free and clear prior to start-up. Finally, verify that all lubrication is fresh and full.

3.0 PIPING

3.1 Split Air Cooled Unit Piping

Refer to the attached Line Sizing chart on page 24 for a guideline for sizing refrigerant lines. The ultimate responsibility for line size selection is that of the installing contractor or project engineer. Data Aire does not assume this responsibility. The chart covers distances up to 200 equivalent feet. For installations beyond this distance, consult ASHRAE or similar references.



Standard piping practice must be used to ensure proper oil return and efficient operation. The interconnecting lines to the remote air cooled condensing unit must be installed by a qualified refrigeration mechanic.

The discharge, suction and liquid lines need to be refrigerant grade copper and in accordance with local code. All refrigeration piping should be installed with high temperature brazed joints. When brazing, a supply of nitrogen gas needs to be fed through the refrigerant lines. Nitrogen needs to be flowing through the lines to eliminate carbon deposit buildup on the inside of the joints which could contaminate the refrigerant and restrict the metering device. Be sure to open the other end of the refrigerant line allowing the nitrogen to bleed off and not cause excess pressure buildup. Data Aire recommends a silver/phosphorus/copper alloy with between 5% and 15% silver be used to braze refrigerant line set to the indoor and outdoor units.

Prevailing good refrigeration practices should be employed for piping support, leak testing, dehydration and charging of the refrigerant circuits. During the installation the lines should be capped off and filled with dry nitrogen at the end of each day's work or until the system is completed and sealed.

Piping must be supported within 18" of the inlet and outlet connections.

3.1.1 Liquid Lines

Liquid line size is determined by pressure drop and velocity. The liquid line pressure drop should not exceed 5 PSI (35 kPa) for R407C or 9 PSI (62 kPa) for R410A. The recommended liquid velocity should be between 200 and 300 FPM (1 to 1.5 m/sec). To avoid excessive liquid line pressure drop, the air cooled condenser should be located above or at the same level as the evaporator. Condenser installations more than 15 feet below the evaporator are not recommended. Insulation of liquid lines is not required but can be useful in preventing excessive sub-cooling or flashing on long exposed pipe runs.

3.1.2 Suction Lines

This unit has the compressor in the condensing unit and requires field piping of liquid and suction lines. Suction lines are trapped similarly to discharge lines. Common practice for suction line selection and installation should be followed. Suction lines should always be insulated.

3.1.3 Connection Sizes, Air Cooled Units

Model	Liquid	Suction
DACU 02	1/2"	3/4"
DACU 03	1/2"	3/4"
DACU 04	1/2"	3/4"
DACU 05	1/2"	3/4"

Note: Unit will have a Liquid Line and Suction Line

 Field connections at the indoor evaporator and remote condensing unit will not necessarily be the same as the field pipe size required. In some cases these sizes will vary significantly.

3.1.4 Field Piping, Remote Condenser/ Condensing Unit Above Evaporator

NOTES:

1. THIS IS THE RECOMMENDED PIPING. ALL PIPING TO BE PER LOCAL AND/OR STATE CODE.
2. CONDENSER TO BE NO MORE THAN 60 FEET ABOVE EVAPORATOR.
3. FOR UNITS BUILT AFTER APRIL 2017, THE CHECK VALVES ARE INCLUDED INTERNALLY IN THE EVAPORATOR SECTION.
4. SLOPE HORIZONTAL LINES DOWNWARD IN THE DIRECTION OF THE REFRIGERANT FLOW, 1/8" FOR EVERY 10 FEET OF LINE LENGTH.
5. INVERTED TRAP TO EXTEND 8" ABOVE THE BOTTOM OF THE CONDENSER COIL. ADDITIONALLY, INVERTED TRAPS ARE NEEDED AT THE TOP OF EVERY GAS LINE RISER.
6. TYPICAL TRAP HEIGHT IS 5-7". LIMIT THE HORIZONTAL SECTION OF THE TRAP TO NO LONGER THAN 8".

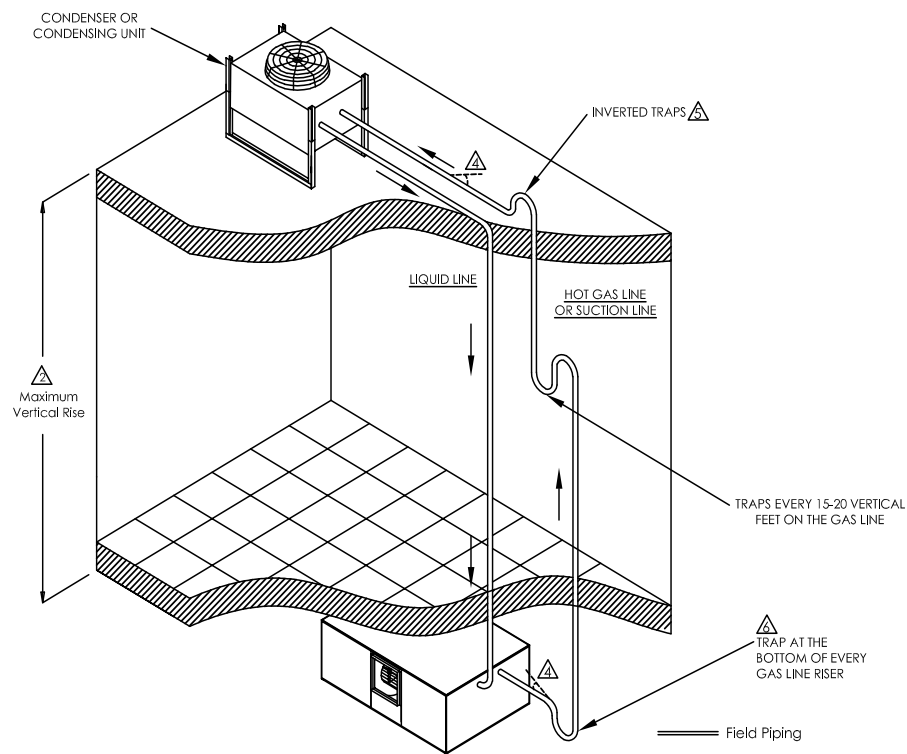

3.1.5 Field Piping, Remote Condenser/ Condensing Unit Below Evaporator

NOTES:

1. THIS IS THE RECOMMENDED PIPING. ALL PIPING TO BE PER LOCAL AND/OR STATE CODE.
 2. CONDENSER TO BE NO MORE THAN 15 FEET BELOW EVAPORATOR.
- ▲ SLOPE HORIZONTAL LINES DOWNWARD IN THE DIRECTION OF THE REFRIGERANT FLOW, 1/2" FOR EVERY 10 FEET OF LINE LENGTH.
- ▲ INVERTED TRAP NEEDED ON SUCTION LINE WHEN COMPRESSOR IS OUTDOORS ONLY.

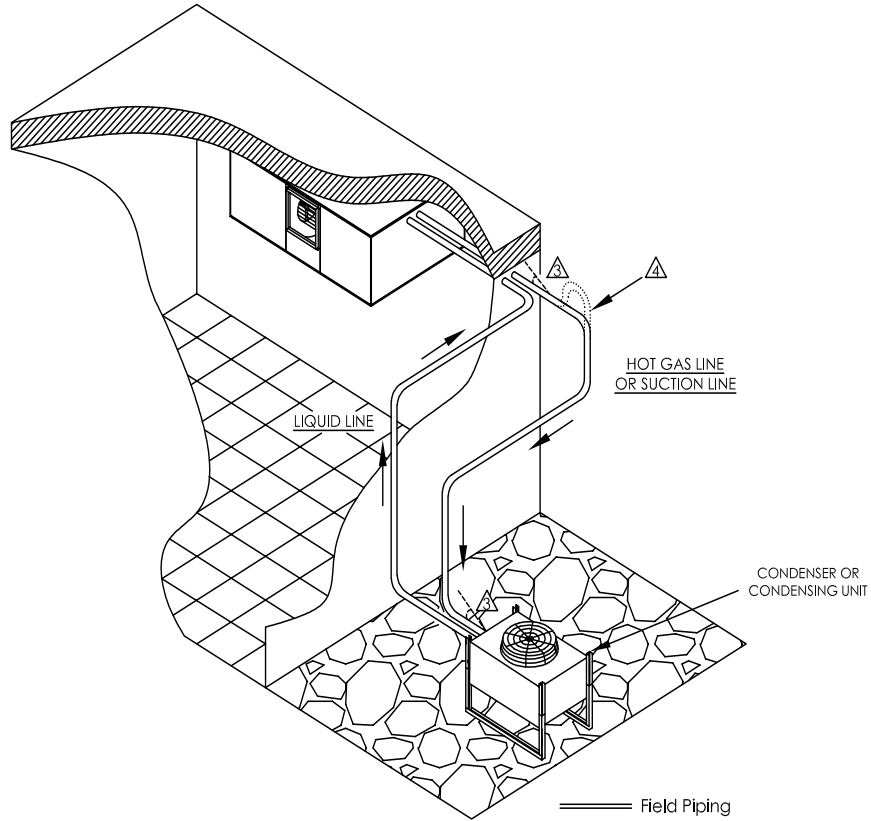

3.2 Water/Glycol Cooled Unit Piping

The required field installed condenser water pipe sizes may or may not be the same as the connection sizes at the evaporator or fluid cooler. This will depend on the length of pipe and the calculated pressure drop of peripheral components.

Remote water cooled condensing units may also be connected to building water or tower water sources. Pipe size will depend on length of run and the maximum water flow required.

Shutoff valves (field provided by others) should be installed within a few feet of the inlet and outlet connections of the evaporator to allow the unit to be isolated for service. A fill valve with a hose bib connection should also be used on the supply line or return line at the unit to allow the unit to be drained.

All water/glycol units are shipped with plate/fin heat exchangers as standard equipment. A strainer is shipped loose and is to be field installed in the supply line with shut-off valves (field provided by others) before and after the strainer. The strainers and water/glycol piping must be cleaned on a periodic basis.

All water pipes have a cap installed on the end of the pipe for pressure testing the system. These caps need to be removed before installing the water piping to the unit. Use a tube cutter for smaller pipes and a reciprocating saw with a metal cutting blade for larger pipe sizes or if there is a clearance problem. All connections need to be cleaned before connections are brazed together.

Water/Glycol system piping may include a centrifugal pump (or pumps for redundancy). Pumps must be primed before operating per the pump manufacturer's guidelines.

NOTE: One of the most common problems in a water/glycol system is the presence of air in the condenser loop. Air vents must be installed in various locations in the piping system to purge air.



One of the most common problems in a water/glycol system is the presence of air in the condenser water loop. Air vents must be installed in various locations in the piping system to purge the air, including the highest point in the water loop.

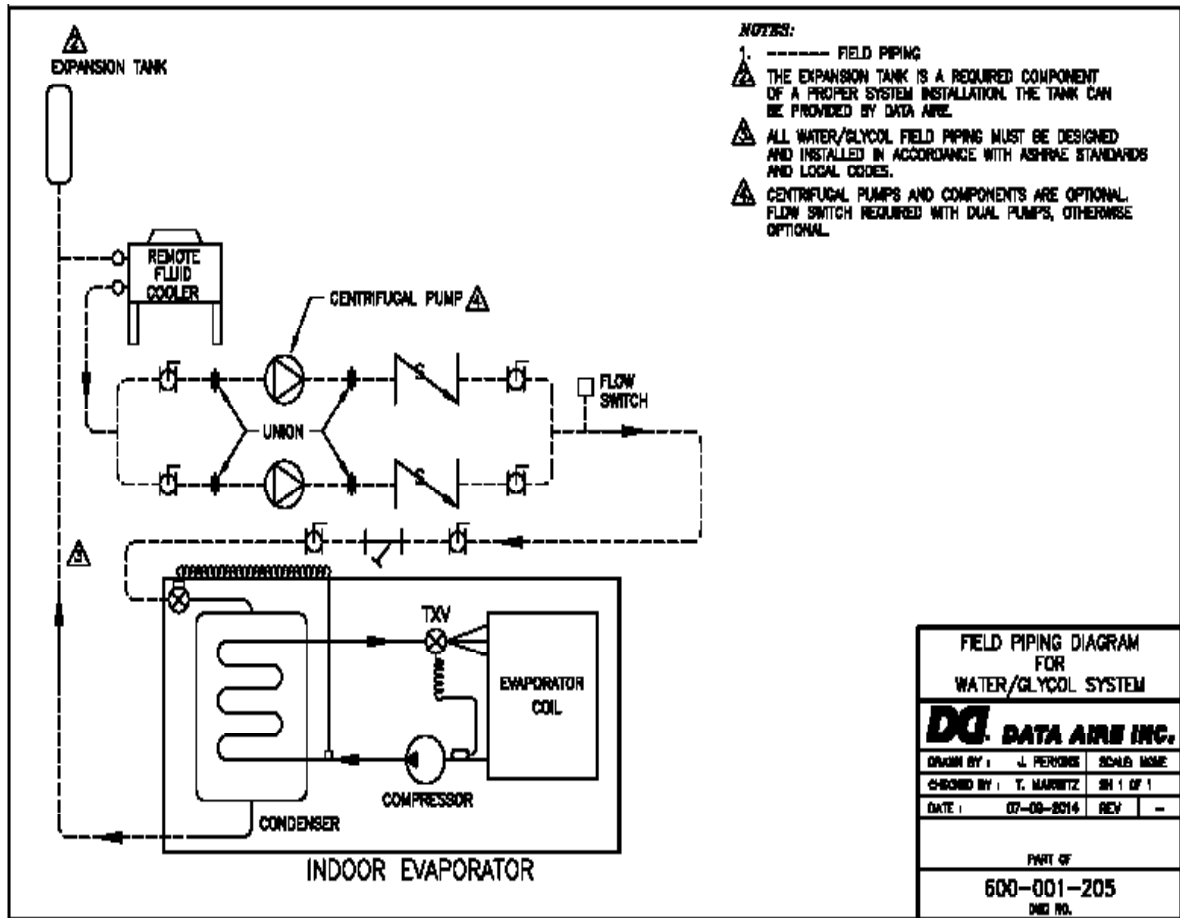

3.2.1 Connection Sizes, Water/Glycol Cooled Units

Evaporator Model	Water IN and OUT Connections, OD
DACW/G 02	3/4"
DACW/G 03	3/4"

3.2.2 Connection Sizes, Fluid Coolers

Fluid Cooler Model	Water IN and OUT Connections, OD
DAFC 06	1-5/8"
DAFC 07	1-5/8"
DAFC 09	1-5/8"
DAFC 11	2-1/8"
DAFC 15	2-1/8"
DAFC 17	2-1/8"

3.3 Chilled Water Piping

Supply and return chilled water connections are sweat copper. The required field installed water pipe sizes may or may not be the same as the connection sizes at the unit. This will depend on the length of pipe and the calculated pressure drop of peripheral components.

Supply and return shutoff valves (field provided by others) are recommended to be installed within a few feet of the supply and return chilled water line connections of the unit. These valves allow ease of maintenance and isolate the unit for service. An in-line strainer (field provided by others) is also recommended. A fill valve with a hose bib connection should also be used on the supply or return lines at the unit to allow the unit to be drained.

Water temperature and worst-case room temperature and humidity conditions should be used to determine whether external piping should be insulated. Typical water temperature is 45° F which is usually cold enough to cause pipes to sweat.

Standard chilled water units have a 3-way chilled water valve. An option for a 2-way valve is also available. In either case the water connections to the unit should be made so there is a counter flow between the water and air. Field water pipe connections are labeled but the counter flow should also be verified before making field connections.

One of the most common problems in a chilled water system is the presence of air in the chilled water loop. Air vents must be installed in various high point locations in the piping system to purge the air. On chilled water units an air vent installed at the top of the coil and can be accessed on the top left side.

WARNING: With any fluid connection there is risk of leakage. Water leakage could result in property damage to mission critical equipment. Water leakage can result from improper installation and/or practices.

3.4 Condensate Drain Piping

The evaporator section is equipped with a 3/4" FPT connection on the bottom for condensate removal. A union is recommended at the field connection which will permit easy disconnection from the unit for cleaning.

A trap should be built into the drain line to prevent air from backing up into the unit. Drain lines should be pitched downward not less than 1/4" for each ten feet of horizontal run. Do not reduce the size of the drain line. Where local codes permit, PVC pipe may be used.

Some applications have no convenient means of allowing a gravity drain. In this case, a condensate pump can be used. These come either factory mounted or shipped loose. Factory mounted condensate pumps do not require a separate power source and the alarm switch is wired to the control system.

Condensate pumps that are not factory mounted ship loose (or field provided) typically require a dedicated 110 volt power source. Always check the pump power requirements before connecting power. Field pipe connections must be made to the pump discharge connection. A check valve must be installed to prevent short cycling.

3.5 Humidifier Piping

The optional humidifier offered on Data Cool is a steam generator type with a disposable cylinder. The humidifier makeup water should be brought to the humidifier through the field connection opening using 1/4" copper tubing. A compression fitting is provided at the humidifier. A shutoff valve should be provided outside the air conditioner to allow disconnection for service. An in-line water pressure regulator and strainer should be installed. Water pressure should be set between 30 and 50 PSI.

The humidifier has a drain at the bottom which is factory piped to the main condensate drain line. The dispersion tube also has a drain line. No additional field piping is required.

3.6 Leak Testing

No installation is complete until the entire system has been thoroughly checked for leaks. This includes checking refrigerant tubing, flare fittings, pressure controls, Schrader TM fittings and compressor Roto-Lock TM service valves.

In addition to the refrigeration system, check all condensate lines, humidifier makeup lines, condensate lines, condensate pumps, chilled water lines, centrifugal pumps and fluid coolers as applicable.

When handling and recovering refrigerant, it is not permissible to release refrigerant into the atmosphere. Many leak-test methods recommended in the past are no longer possible. Current standard practices must be used.

Pressurize system circuit to 150 PSIG (1034kPa) by using dry nitrogen with a trace of refrigerant. Check the entire system for leaks with suitable leak finder, (per local code) including but limited to all braze joints, caps, fittings and flare nuts on both field and factory furnished components. After completion of leak testing, release test pressure and pull a vacuum on the system.



WARNING: Tightening of fittings and valves is the responsibility of the installing contractor.

3.7 Evacuation

Evacuate the refrigerant lines, condenser coil and evaporator coil to 250 microns or lower (a micron gauge and 2-stage vacuum pump are required). Valve off and turn off the vacuum pump and wait for at least fifteen minutes to make sure the micron gauge reading does not go back up above 700 microns. If it does, re-start the vacuum pump and evacuate until the system reaches 250 microns. If the system still does not hold the pressure below 700 microns the system needs to be rechecked for leaks.

After the system has been satisfactorily evacuated the unit can be charged with refrigerant. Connect the pressure gauge manifold set to the high and low ports near the compressor, connect the charging line to the refrigerant tank and set it for liquid feed. Open the refrigerant tank valve and purge the line at the manifold, then open the high side valve on the manifold only, and allow the refrigerant to flow until the system pressure equalizes. At this point the system will have 75 to 80% of the total refrigerant charge. Start the fans and then the compressor checking the operating pressure and temperatures.



WARNING: Do not apply power to the compressor when in a vacuum.

4.0 ELECTRICAL CONNECTIONS



WARNING: The Data Aire cooling unit must be connected by a licensed and qualified electrician. Risk of electrical shock could result in injury or death. Disconnect all remote electrical power supplies prior to working on the unit. Before proceeding with the electrical connections, make certain that the volts, hertz and phase correspond to that specified on the unit electrical nameplate. Units damaged from incorrect power input will not be covered under warranty. Use copper conductors only.

4.1 Electrical Service

Check to be sure the service provided by the utility is sufficient to handle the additional load imposed by this equipment. Indoor unit has a single power source. Indoor split units typically have a single power source but can also be provided with separate sources. Field-provided, interconnecting control wires are also required. Units with outdoor secondary heat exchangers will require a separate power source and field-provided, interconnecting control wires as well. See section 3.5 below.

Remote outdoor condensing units require one power source. Glycol systems with fluid coolers and loose pump(s) typically require one power source for the fluid cooler and will require one additional source for a single pump or two additional sources for dual pumps. Systems where the pump(s) are mounted and piped integral to the fluid cooler will usually require a single power source.

4.2 Nameplate Ratings

Refer to the unit electrical nameplate for equipment electrical requirements. Minimum Circuit Ampacity (MCA), also known as Wire Sizing Amps, will dictate the minimum required wire gauge. Maximum Overcurrent Protection (MOP) Device amps will dictate the maximum circuit breaker or fuse size.

4.3 Grounding

The unit cabinet must have an uninterrupted true earth ground. An electrical ground wire of adequate size must be connected to the ground lug provided inside the main electrical box.

4.4 Voltage Tolerance

The supply voltage to the unit must be within tolerance of -5% +10% for 208-230 voltage, +/- 10% for 460 voltage. The local utility company should be contacted for correction of improper line voltage. Deviation from voltage ratings can cause premature failures and possibly void unit warranties

WARNING: Check the wiring connections in the unit control panel to ensure they are tight. Screw terminals may come loose in transit. Tightening of wiring connections is the responsibility of the installing contractor.

4.5 Auxiliary Control Wiring

The outdoor condensing unit requires its own power source and ground source. A disconnect (field provided) is required to be installed to isolate the unit for maintenance and service. Check nameplate voltage ratings to ensure field power (building power).

A field supplied 3 or 4 wire control connection (24 VAC) is required between the evaporator and the condensing unit. All control wiring must be installed in accordance with the National Electrical Code (NEC) Class 1 circuit. See the unit schematic for control wiring details.



Check the wiring connections in the unit control panel to ensure they are tight. Screw terminals may become loose in transit. Tightening of wiring connections is the responsibility of the installing contractor.

5.0 INSTALLATION OF REMOTE OUTDOOR HEAT EXCHANGER

NOTE: Air cooled condenser and fluid coolers have individual Installation, Operation and Maintenance manuals which should be referred to for more complete details.

6.0 CHARGING

6.1 Voltage Phase Check

6.1.1 Evaporator

Data Cool units are single phase only therefore no need for a phase check on the evaporator section.

6.1.2 Condensing Units

Although the scroll compressor is phase dependent, units shipped from the factory are run tested, ensuring the compressor rotation is consistent with the evaporator fan motor. However, a field change-out the compressor may require checking proper phase. An out-of-phase compressor will draw relatively low amps and both suction and discharge pressures will remain nearly equal.

6.1.3 Secondary Heat Exchanger

The secondary heat exchanger may be ordered as three phase but the individual fan motors are single phase and will only run in one direction. Check operation by placing a momentary jumper across low voltage terminals #39 and #40 (disconnect pumps on glycol systems unless already filled with water/glycol solution). Placing a jumper across terminal #39 and #40 will energize the control circuit. Fans may not run because the thermostat is above the current ambient or the #1 fan on air cooled condensers with fan speed control has not reacted to the head pressure. The fan will not run until the head pressure is well over 200 PSIG.

6.2 Air Cooled Systems

6.2.1 Split Indoor Air Cooled Systems Charging

After the field refrigerant piping is properly completed, connect the refrigerant drum to the low side and charge with vapor. For systems with R-407C, charge with approximately 2.55 lbs. per nominal ton. Systems with R-410A require 3 lbs. per nominal ton.

It is likely that more refrigerant will be required to complete the charging procedure. Make sure all hoses are properly purged. From a vacuum, feed liquid refrigerant into the high side of the system until the pressures equalize. At this point there will be about 70-80% of the total charge in the system.



Before starting a compressor, the crankcase heater should be energized for a minimum of 12 hours to reduce the possibility of liquid slugging on start-up. Failure to energize the crankcase heater could result in compressor damage.

Start the evaporator fan and compressor. Check the liquid line sight glass to get a feel for the approximate charge. Bubbles in the sight glass are not unusual at this point and can be caused by flashing from liquid line pressure drop, low sub-cooling or low charge. It is likely that more refrigerant will be required to complete the charging procedure.

Adjust the refrigerant charge until the subcooling is between 8° F and 10° F and the superheat is between 8° F and 15° F. There may be flashing and/or bubbles in the sight glass when the system is properly charged. The unit should be allowed to stabilize for several minutes before meaningful measurements can be taken.

A properly charged system operating at typical parameters will have the following pressures:

Units with R-407C:

Head pressure 240 – 295 PSIG Suction Pressure 58 PSIG or greater

Units with R-410A:

Head pressure 340 – 415 PSIG Suction pressure 104 – 121 PSIG

The superheat at the compressor suction line at least 6 inches away from the compressor should be 8-15°.



Note: Charging to a full liquid line sight glass should never be the sole means of determining the correct refrigerant charge. Other parameters such as superheat, suction pressure, head pressure, sub-cooling and ambient temperature are also important parameters. A system charged to a clear sight glass is often overcharged.

6.2.2. Fan Speed Control System Charging

The standard outdoor air cooled condensing for Data Aire equipment is a fan speed control system. After the field refrigerant piping is properly completed, connect the refrigerant drum to the low side and charge with vapor. For systems with R-407C, charge with approximately 2.55 lbs. per nominal ton. Systems with R-410A require 3 lbs. per nominal ton.

It is likely that more refrigerant will be required to complete the charging procedure. Make sure all hoses are properly purged. From a vacuum, feed liquid refrigerant into the high side of the system until the pressures equalizes. At this point there will be about 70-80% of the total charge in the system.



Before starting a compressor, if the system has a refrigerant holding charge, the crankcase heater should be energized for a minimum of 12 hours to reduce the possibility of liquid slugging on start-up. Failure to energize the crankcase heater could result in compressor damage. If the system is charged and started from a vacuum, the preheating of the compressor is not necessary.

Start the evaporator fan and compressor. Check the liquid line sight glass to get a feel for the approximate charge. Bubbles in the sight glass are not unusual at this point and can be caused by flashing from liquid line pressure drop, low sub-cooling or low charge. It is likely that more refrigerant will be required to complete the charging procedure.

Adjust the refrigerant charge until the subcooling is between 8°F and 10°F and the superheat is between 8°F and 15°F. There may be flashing and/or bubbles in the sight glass when the system is properly charged. The unit should be allowed to stabilize for several minutes before meaningful measurements can be taken.

After the system is allowed to stabilize, verification of a key few measurements should be noted. Adjust the refrigerant charge until to a sub-cooling of 8 to 10° and has sparse bubbles.

A properly charged system operating at typical parameters will have the following pressures:

Units with R-407C:

Head pressure 240 – 295 PSIG Suction Pressure 58 PSIG or greater

Units with R-410A:

Head pressure 340 – 415 PSIG Suction pressure 104 – 121 PSIG

The superheat at the compressor suction line at least 6 inches away from the compressor should be 8 – 15 degrees.



Note: Charging to a full liquid line sight glass should never be the sole means of determining the correct refrigerant charge. Other parameters such as superheat, suction pressure, head pressure, sub-cooling and ambient temperature are also important parameters. A system charged to a clear sight glass is often overcharged.

6.3 Water/Glycol Cooled Split Systems

6.3.1. Water/Glycol Cooled Split Systems Charging

All water/glycol Data Cool units are split systems requiring field charge. After the refrigerant piping and water line piping is properly completed, connect the refrigerant drum to the low side and charge with vapor.



Before starting a compressor, the crankcase heater should be energized for a minimum of 12 hours to reduce the possibility of liquid slugging on start-up. Failure to energize the crankcase heater could result in compressor damage.

Start the evaporator fan and compressor. Check the liquid line sight glass to get a feel for the approximate charge. Bubbles in the sight glass are not unusual at this point and can be caused by flashing from liquid line pressure drop, low sub-cooling or low charge. It is likely that more refrigerant will be required to complete the charging procedure.

Adjust the refrigerant charge until the subcooling is between 8° F and 10° F and the superheat is between 8° F and 15° F. There may be flashing and/or bubbles in the sight glass when the system is properly charged. The unit should be allowed to stabilize for several minutes before meaningful measurements can be taken.

A properly charged system operating at typical parameters will have the following pressures:

Units with R-407C:

Head pressure 240 – 295 PSIG Suction Pressure 58 PSIG or greater

Units with R-410A:

Head pressure 340 – 415 PSIG Suction pressure 104 – 121 PSIG

The superheat at the compressor suction line at least 6 inches away from the compressor should be 8 – 15 degrees.



Note: Charging to a full liquid line sight glass should never be the sole means of determining the correct refrigerant charge. Other parameters such as superheat, suction pressure, head pressure, sub-cooling and ambient temperature are also important parameters. A system charged to a clear sight glass is often overcharged.

The water regulating valve should be adjusted to maintain 230 to 260 psi head pressure for a R407C system or 300 to 340 psi head pressure for a R 410A system. Suction pressure should be 58 psi or greater. The superheat at the compressor suction line at least 6 inches away from the compressor should be 8-15°.

It is necessary to measure and note proper unit operation including superheat, head and suction pressure. Some adjustment to charge may be required.

All water/glycol cooled units have a water regulating valve. A head pressure sensing transducer is connected to a schrader fitting on the discharge line and water is regulated into the condenser coil. Standard condensers are plate fin type.

6.4 Refrigerant Handling

The use of recovery/recycling units is required by U.S. Environmental Protection Agency (EPA) regulations. Technicians who service and dispose of air conditioning and refrigeration equipment must recover the refrigerant instead of venting to atmosphere.

Except for extremely small releases of refrigerant such as what occurs when disconnecting service hoses (diminutive release), a technician who knowingly releases or vents refrigerant to the atmosphere is in violation of these regulations. Freon purchasers must be certified technicians and have a valid EPA certification card.

6.5 Important Refrigeration Components

6.5.1 Expansion Valve

Each refrigerant circuit has an adjustable thermo-expansion valve (TXV). These are factory adjusted to their nominal rating. Any field adjustment should be to fine tune a system that has stabilized and already has acceptable operating parameters.

6.5.2 High Pressure Cutout Switch

Each refrigerant circuit is protected by a high head pressure cutout switch with a manual reset button. The cutout pressure rating for refrigerant R 407C is 450 psi or R 410A is 575 psi. Physical location is near the compressor which is in or the condensing section.

6.5.3 Low Pressure Cutout Switch

Each circuit also contains a low suction pressure cutout switch with automatic reset. The switch is located near the compressor section. The pressure rating for R-407C systems is 30 PSIG. The pressure rating for R-410A systems is 50 PSIG.

7.0 CONTROLS

7.1 Thermostat

Each Data Cool unit is shipped with a cooling only digital thermostat designed to provide accurate control, displays room temperature and cooling on mode. The six buttons on the front of the thermostat allow complete control of the equipment.

Setpoints - Raising and lowering the setpoints is accomplished by simply pushing the "Up" or "Down" buttons. The unit will display either Fahrenheit or Celsius.

Cooling - Select the temperature by pressing the "Up" or "Down" button. The word "COOL" and the temperature setting is Displayed for five seconds.

21 Fahrenheit/Celsius - Simultaneously press the "Up" and "Down" buttons to switch between Fahrenheit and Celsius temperature setpoint.

Follow the provided wiring diagram.

7.2 Programmable Digital Thermostat

A cooling only digital thermostat designed to provide accurate control, displays room temperature and cooling on mode. The buttons on the front of the thermostat allow complete control of the equipment.

Cooling - Select the temperature by pressing the “Up” or “Down” button. The word “COOL” and the temperature setting is displayed for five seconds.

Fahrenheit/Celsius - Simultaneously press the “Up” and “Down” buttons to switch between Fahrenheit and Celsius temperature set point.

In addition, the thermostat can be programmed for two or four events per day. The events will allow program of a day and night setting. Four events will allow programming of a morning, day, evening and night settings. See the enclosed booklet (Uni-Line 110-809C) for programming details.

Follow the provided wiring diagram.

7.3 Optional Mini dap4 Microprocessor Control Panel

The Mini dap4 microprocessor control panel is an optional control panel available as an upgrade to the thermostat. There is a separate manual that goes into extensive detail regarding functions, features, programming and troubleshooting.



The Mini dap4 microprocessor control panel has an entire manual dedicated to its use and operation. This manual must be referenced to complete a thorough unit installation. Start-up is not complete until the Mini dap4 control panel settings are established.

7.4 Optional Expanded dap4 Microprocessor Control Panel

The dap4 microprocessor control panel is available as an upgrade to the Mini dap4 panel and offers additional features. There is a separate manual that goes into extensive detail regarding functions, features, programming and troubleshooting.



The dap4 microprocessor control panel has an entire manual dedicated to its use and operation. This manual must be referenced to complete a thorough unit installation. Start-up is not complete until the DAP II control panel settings are established.

7.5 Wiring Diagrams

Every Data Aire evaporator and condensing unit or fluid cooler comes with a wiring diagram. These diagrams are ‘ladder’- type schematics intended for service personnel. The intent is to allow the technician to understand the wiring details associated with the electrical components and how they interface with the controls as well as peripheral equipment, including secondary heat exchangers.

The wiring diagram in the evaporator will indicate field interface terminals to the secondary heat exchanger. The internal wiring of the heat exchanger is found on a separate diagram which can be found on the inside cover of the heat exchanger electrical box. Both diagram types are also placed inside the shipping/warranty packet that is placed inside the evaporator.

8.0 REGULAR MAINTENANCE ITEMS

8.1 Air Filters

Air filters should be checked on a regular basis and changed when they become dirty. This will ensure efficient operation of the unit. Spare air filters should be kept in stock as these tend to be a frequently replaced maintenance item. Air filters may require changing as often as monthly. Note also that construction dust on new installations will quickly clog new filters.



Air filters that require changing can restrict airflow and create problems such as coil icing or poor air distribution.

8.2 Bearings

Blower bearings used on Data Cool units are permanently lubricated and do not require maintenance.

8.3 Humidifier Canisters

The optional steam generator type humidifier does not require maintenance other than to replace the canister as required. This frequency will depend on usage and water type. A set of manufacturer's instructions for the humidifier is sent as part of the paperwork placed inside the unit when it ships.

8.4 Fuses

Fuses may occasionally require changing especially with installations where the voltage is not consistent. Drops in voltage can create brief periods of high amp draw, causing fuses to blow. Always replace fuses with those of the equivalent rating with regard to: 1) amperage, 2) voltage, and 3) speed. For instance compressors and motors are inductive loads which require time delay fuses. Electric reheat and humidifiers are resistive loads requiring fast acting fuses.

8.5 Heating Elements

The optional heating elements do not normally require maintenance. However sometimes they may accumulate a film of dust or dirt when unused for extended periods of time. When energized, the burning debris can create smoke or unpleasant odor. To help avoid this, periodic cleaning is recommended.

8.6 Refrigerant Filter Drier

Factory installed refrigerant filter driers do not normally require maintenance. When replacing compressors or other repairs that open the refrigeration system to atmosphere, it is advisable to replace the filter drier. The equivalent type and size should be used.

9.0 Contact Data Aire

Address:

DATA AIRE INC.
230 W. BLUERIDGE AVE.
ORANGE, CA 92865

Phone:

714-921-6000
800-347-AIRE (2473) Toll Free

Fax:

714-921-6010	Main
714-921-6011	Engineering
714-921-6022	Part Sales

E-mail:

service@dataaire.com	Technical Support
engineering@dataaire.com	Engineering
sales@dataaire.com	Sales

Web site: www.dataaire.com

Job Information:

Data Aire Job Number: _____

Evaporator Serial Number: _____

Evaporator Model Number: _____

Condensing Unit/

Fluid Cooler Serial Number: _____

CondenserUnit/Fluid Cooler Model Number: _____

Date installed: _____ / _____ / 20____

Installing Contractor: _____

RECOMMENDED LINE SIZING FOR AIR COOLED SPLIT SYSTEMS UP TO 200 EQUIVALENT FEET

LIQUID LINES					
SINGLE CIRCUIT SYSTEMS					
Unit Tonnage	Tons per Circuit	EQUIVALENT FEET			
		50	100	150	200
2	2	3/8	1/2	1/2	1/2
3	3	1/2	1/2	1/2	1/2

SUCTION LINES									
SINGLE CIRCUIT SYSTEMS									
Unit Tonnage	Tons per Circuit	EQUIVALENT FEET							
		50		100		150		200	
		HOR	VER	HOR	VER	HOR	VER	HOR	VER
2	2	7/8	7/8	7/8	7/8	7/8	7/8	1-1/8	7/8
3	3	7/8	7/8	1-1/8	7/8	1-1/8	7/8	1-1/8	7/8

HOR = HORIZONTAL

VERT = VERTICAL



Monthly Maintenance Inspection Checklist

Model No. _____
Prepared by: _____

Serial No. _____
Date: ____ / ____ / 20__

Air Filters

___ Check for restricted air flow

Electrical Panel

___ Check contactor operation

Blower Section

___ Blower wheel free of debris moves freely
___ Check motor mounts

Notes: _____

Air Distribution Section

___ Check for restriction in grille(s)

Air Cooled Condensing Unit (if applicable)

___ Condensing coil clean
___ Motor Mounts tight
___ Motor fan bearings in good condition
___ Refrigeration lines properly supported

Compressor

___ Check crank case temperature

Refrigeration Cycle/Section

___ Check for leaks

Water/Glycol Fluid Cooler (if applicable)

___ Water regulating valve function
___ Check for water/glycol leaks (piping area)

Glycol Pump(s) (if applicable)

___ Glycol leaks (pump area)
___ Pump operation
___ Auto air vent clean of mineral deposits

Condensate Drain and Pump (if applicable)

___ Check for water leaks
___ Check for restricted air flow
___ Pump operation

Steam Generating Humidifier (if applicable)

___ Check canister for deposits and water
___ level, replace if necessary
___ Check condition of steam hose and clamps

Quarterly Maintenance Inspection Checklist

Model No. _____
Prepared by: _____

Serial No. _____
Date: ___ / ___ / 20__

Air Filters

- ___ Check for restricted air flow
- ___ Wipe filter rack section clean

Blower Section

- ___ Blower wheel free of debris and moves freely
- ___ Check air flow safety switch operation
- ___ Check motor mounts

Air Distribution Section

- ___ Check for restriction in grille(s)

Air Cooled Condensing Unit (if applicable)

- ___ Condenser coil clean
- ___ Motor mounts tight
- ___ Motor fan bearings in good condition
- ___ Refrigeration lines properly supported
- ___ Heated receiver site

Refrigeration Cycle/Section

- ___ Check for moisture (site glass)
- ___ Check suction pressure
- ___ Check discharge pressure
- ___ Check hot gas bypass valve operation
- ___ Check thermostatic expansion valve operation
- ___ Check solenoid valve operation
- ___ Check for leaks

Compressor

- ___ Check crankcase heater operation

Water/Glycol Fluid Cooler (if applicable)

- ___ Water regulating valve function
- ___ Check solution _____%
- ___ Check for water/glycol leaks (piping area)
- ___ Water/Glycol flow switch operational

Glycol Pump(s) (if applicable)

- ___ Glycol leaks (pump area)
- ___ Pump operation
- ___ Auto air vent clean of mineral deposits

Condensate Drain and Pump (if applicable)

- ___ Check for water leaks and restricted flow
- ___ Pump operation

Steam Generating Humidifier (if applicable)

- ___ Check canister for deposits and water level
- ___ Check condition of steam hose and clamps
- ___ Check drain and fill valve for deposits

Reheat (if applicable)

- ___ Check reheat element(s) for dust
- ___ Check high limit switch operation

Electrical Panel

- ___ Check fuses
- ___ Check contactor operation
- ___ Check all electrical connections
- ___ Check operation sequence

Mini dap4 control panel operations (Optional)

- ___ Check calibration of temperature sensor
- ___ Check calibration of humidity sensor
- * Mini dap4 menu options

Equipment Runtimes

Blower	_____	hrs
Condenser	_____	hrs
Compressor	_____	hrs
Reheat	_____	hrs
Humidifier	_____	hrs
Dehumidification	_____	hrs
Energy Saver	_____	hrs

___ Reset all to read zero runtimes

Temperature/Humidity set at: _____ ° _____ % RH

Notes:

Data Cool

*Air, Water and Glycol Cooled DX and Chilled Water
2 and 3 Ton*

Installation, Operation & Maintenance Manual



Data Aire, Inc. | 230 W. BlueRidge Avenue | Orange, CA 92865 | www.dataaire.com

ISO 9001-2008 Certified | ©Copyright 2017 Data Aire, Inc. | A member of the CS Group of Companies | Making Products That Make Building Better